

Características

Conexión 1	Rosca de tuerca métrica
Forma de obturación 1	Tubuladura premontada
Conexión 2 + 3	Rosca exterior métrica, cilíndrica
Forma de obturación 2 + 3	Cono interior de 24°
Construcción	Racor, dirección ajustable
Forma constructiva	en L
Norma	DIN 2353 ISO 8434-1
Volumen de suministro	Tubuladura con tuerca de racor y anillo cortante
Material	Acero
Protección de la superficie	con revestimiento galvanizado

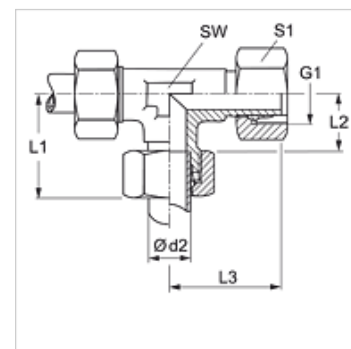

Nota

Para obtener información acerca del montaje, la instalación, la carga de presión y las temperaturas de servicio admisibles, consulte la Información técnica de los racores de tubo.

Artículo

Denominación	Serie	Presión de servicio en bar	Ø d2 (mm)	G1	L1 (mm)	L2 (mm)	L3 (mm)	SW (mm)	S1
VEL 16 LL	LL	PN 100	16	M 22 x 1,5	36	21,0	21,0	19	27
VEL NW 04 HL	L	PN 315	6	M 12 x 1,5	27	12,0	26,0	12	14
VEL NW 06 HL	L	PN 315	8	M 14 x 1,5	29	14,0	27,0	12	17
VEL NW 08 HL	L	PN 315	10	M 16 x 1,5	30	15,0	28,5	14	19
VEL NW 10 HL	L	PN 315	12	M 18 x 1,5	32	17,0	29,0	17	22
VEL NW 13 HL	L	PN 315	15	M 22 x 1,5	36	21,0	32,0	19	27
VEL NW 16 HL	L	PN 315	18	M 26 x 1,5	40	23,5	35,0	24	32
VEL NW 20 HL	L	PN 160	22	M 30 x 2	44	27,5	38,0	27	36
VEL NW 25 HL	L	PN 160	28	M 36 x 2	47	30,5	41,5	36	41
VEL NW 32 HL	L	PN 160	35	M 45 x 2	56	34,5	51,0	41	50
VEL NW 40 HL	L	PN 160	42	M 52 x 2	63	40,0	56,0	50	60
VEL NW 03 HS	S	PN 630	6	M 14 x 1,5	31	16,0	27,0	12	17
VEL NW 04 HS	S	PN 630	8	M 16 x 1,5	32	17,0	27,0	14	19
VEL NW 06 HS	S	PN 630	10	M 18 x 1,5	34	17,5	29,5	17	22
VEL NW 08 HS	S	PN 630	12	M 20 x 1,5	38	21,5	30,5	17	24
VEL NW 10 HS	S	PN 630	14	M 22 x 1,5	40	22,0	34,5	19	27
VEL NW 13 HS	S	PN 400	16	M 24 x 1,5	43	24,5	36,0	24	30
VEL NW 16 HS	S	PN 400	20	M 30 x 2	48	26,5	44,0	27	36
VEL NW 20 HS	S	PN 400	25	M 36 x 2	54	30,0	49,5	36	46
VEL NW 25 HS	S	PN 400	30	M 42 x 2	62	35,5	55,0	41	50
VEL NW 32 HS	S	PN 315	38	M 52 x 2	72	41,0	63,0	50	60

Serie: LL = muy ligero L = ligero S = pesado - PN = presión nominal PB = presión de servicio máx. - Ø d2 = diámetro exterior del tubo

Variantes de producto

VEL MG	Racor, en L, Latón
VEL VA	Racor, en L, Acero fino
XVEL	Racor, en L, Acero