

Características

Conexión 1	Rosca de tuerca métrica
Construcción	Tuerca de racor
Norma	DIN 3870
Material	Acero
Protección de la superficie	con revestimiento galvanizado

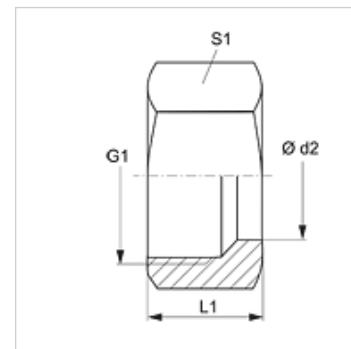
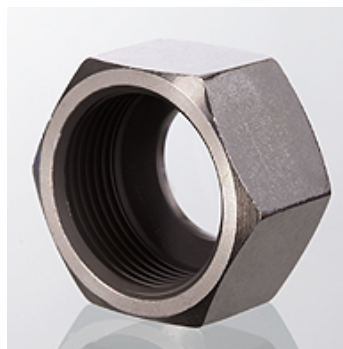

Artículo

Denominación	Serie	Ø d2 (mm)	G1	L1 (mm)	S1
UEM 04 LL	LL	4,0	M 8 x 1	11,5	10
UEM 05 LL	LL	5,0	M 10 x 1	12,0	12
UEM 06 LL	LL	6,0	M 10 x 1	12,0	12
UEM 08 LL	LL	8,0	M 12 x 1	12,5	14
UEM 10 LL	LL	10,0	M 14 x 1	13,5	17
UEM 12 LL	LL	12,0	M 16 x 1	13,5	19
UEM 16 LL	LL	16,0	M 22 x 1,5	17,5	27
UEM NW 04 L	L	6,0	M 12 x 1,5	15,0	14
UEM NW 06 L	L	8,0	M 14 x 1,5	15,0	17
UEM NW 08 L	L	10,0	M 16 x 1,5	16,0	19
UEM NW 10 L	L	12,0	M 18 x 1,5	16,0	22
UEM NW 13 L	L	15,0	M 22 x 1,5	17,5	27
UEM NW 16 L	L	18,0	M 26 x 1,5	18,5	32
UEM NW 16 L 27	L	18,0	M 27 x 2	18,0	32
UEM NW 20 L	L	22,0	M 30 x 2	20,5	36
UEM NW 25 L	L	28,0	M 36 x 2	21,5	41
UEM NW 32 L	L	35,0	M 45 x 2	24,5	50
UEM NW 40 L	L	42,0	M 52 x 2	24,5	60
UEM NW 03 S	S	6,0	M 14 x 1,5	17,0	17
UEM NW 04 S	S	8,0	M 16 x 1,5	17,0	19
UEM NW 06 S	S	10,0	M 18 x 1,5	18,0	22
UEM NW 08 S	S	12,0	M 20 x 1,5	18,0	24
UEM NW 10 S	S	14,0	M 22 x 1,5	21,0	27
UEM NW 13 S	S	16,0	M 24 x 1,5	21,0	30
UEM NW 16 S	S	20,0	M 30 x 2	24,5	36
UEM NW 20 S	S	25,0	M 36 x 2	27,5	46
UEM NW 25 S	S	30,0	M 42 x 2	29,5	50
UEM NW 32 S	S	38,0	M 52 x 2	33,0	60

Serie: LL = muy ligero L = ligero S = pesado - PN = presión nominal PB = presión de servicio máx. - Ø d2 = diámetro exterior del tubo

Variantes de producto

UEM VA	Tuerca de racor, VA, Acero fino
UEM MG	Tuerca de racor MG, Latón