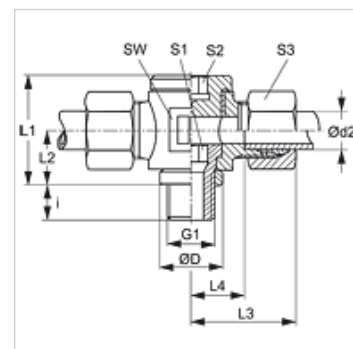

Características

Conexión 1	Rosca exterior métrica, cilíndrica
Forma de obturación 1	Junta de estanqueidad
Conexión 2 + 3	Rosca exterior métrica, cilíndrica
Forma de obturación 2 + 3	Cono interior de 24°
Construcción	Racor giratorio sin estrangulación
Forma constructiva	en T
Norma	DIN 3865
Volumen de suministro	Tubuladura con tuerca de racor y anillo cortante
Material	Acero
Protección de la superficie	con revestimiento galvanizado

**Nota**

Para obtener información acerca del montaje, la instalación, la carga de presión y las temperaturas de servicio admisibles, consulte la Información técnica de los racores de tubo.

Artículo

Denominación	Serie	Presión de servicio en bar	Ø d2 (mm)	G1	Ø D (mm)	i (mm)	L1 (mm)	L2 (mm)	L3 (mm)	L4 (mm)	SW (mm)	S1	S2	S3
DTM NW 04 HL	L	PN 160	6	M 10 x 1	14	8	24	12	27	12,0	19	6	6	14
DTM NW 06 HL	L	PN 160	8	M 12 x 1,5	17	12	27	14	28	13,0	22	6	6	17
DTM NW 08 HL	L	PN 100	10	M 14 x 1,5	19	12	30	15	30	15,0	22	8	8	19
DTM NW 10 HL	L	PN 100	12	M 16 x 1,5	21	12	36	18	32	17,5	27	10	10	22
DTM NW 13 HL	L	PN 100	15	M 18 x 1,5	23	12	39	19	35	20,0	30	12	12	27
DTM NW 16 HL	L	PN 100	18	M 22 x 1,5	27	14	41	20	37	20,5	32	14	14	32
DTM NW 20 HL	L	PN 100	22	M 26 x 1,5	31	16	46	22	41	24,5	36	17	17	36
DTM NW 25 HL	L	PN 100	28	M 33 x 2	39	18	58	29	46	29,5	46	22	22	41
DTM NW 32 HL	L	PN 63	35	M 42 x 2	49	20	69	33	55	33,0	55	27	27	50
DTM NW 40 HL	L	PN 63	42	M 48 x 2	55	22	84	41	63	40,0	70	32	32	60
DTM NW 03 HS	S	PN 160	6	M 12 x 1,5	17	12	27	14	30	15,0	22	6	6	17
DTM NW 04 HS	S	PN 160	8	M 14 x 1,5	19	12	30	15	31	16,0	22	8	8	19
DTM NW 06 HS	S	PN 100	10	M 16 x 1,5	21	12	36	18	34	18,0	27	10	10	22
DTM NW 08 HS	S	PN 100	12	M 18 x 1,5	23	12	39	19	36	26,0	30	12	12	24
DTM NW 10 HS	S	PN 100	14	M 20 x 1,5	25	14	41	20	40	22,0	32	12	12	27
DTM NW 13 HS	S	PN 100	16	M 22 x 1,5	27	14	45	22	42	23,5	36	14	14	30
DTM NW 16 HS	S	PN 100	20	M 27 x 2	32	16	58	28	50	28,5	46	17	17	36
DTM NW 20 HS	S	PN 100	25	M 33 x 2	39	18	62	31	55	31,0	50	22	22	46
DTM NW 25 HS	S	PN 63	30	M 42 x 2	49	20	74	36	63	36,5	60	27	27	50
DTM NW 32 HS	S	PN 63	38	M 48 x 2	55	22	84	41	72	41,0	70	32	32	60

Serie: LL = muy ligero L = ligero S = pesado – PN = presión nominal PB = presión de servicio máx. – Ø d2 = diámetro exterior del tubo

Variantes de producto

DTM VA	Racor giratorio sin estrangulación, en T, Acero fino
XDTM	Racor giratorio sin estrangulación, en T, Acero