

Características

Conexión 1	Rosca exterior métrica, cilíndrica
Forma de obturación 1	Cono interior de 24°
Conexión 2	Rosca exterior métrica, cilíndrica
Forma de obturación 2	Cono interior de 24°
Construcción	Racor giratorio (conector de paso)
Suplemento construcción	Rodamiento de bolas
Forma constructiva	recto
Volumen de suministro	Tubuladura (sin tuerca de racor ni anillo cortante)
Material	Acero
Protección de la superficie	con revestimiento galvanizado

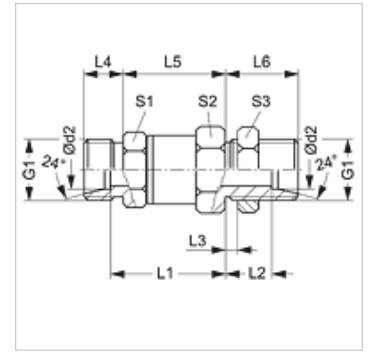

Nota

Para obtener información acerca del montaje, la instalación, la carga de presión y las temperaturas de servicio admisibles, consulte la Información técnica de los racores de tubo.

Artículo

Denominación	Serie	Presión de servicio en bar	Ø d2 (mm)	G1	L1 (mm)	L2 (mm)	L3 (mm)	L4 (mm)	L5 (mm)	L6 (mm)	S1	S2	S3
DGS NW 06 HL	L	PN 315	8	M 14 x 1,5	40,0	16,0	5	10	37,0	23,0	19	22	17
DGS NW 08 HL	L	PN 315	10	M 16 x 1,5	50,0	16,0	5	11	46,0	23,0	24	30	22
DGS NW 10 HL	L	PN 315	12	M 18 x 1,5	50,0	16,0	5	11	46,0	23,0	24	30	24
DGS NW 13 HL	L	PN 315	15	M 22 x 1,5	51,0	19,0	5	12	46,0	26,0	24	30	30
DGS NW 16 HL	L	PN 315	18	M 26 x 1,5	61,0	28,0	15	12	56,5	35,5	36	41	36
DGS NW 20 HL	L	PN 160	22	M 30 x 2	63,0	30,5	15	14	56,5	38,0	36	41	41
DGS NW 25 HL	L	PN 160	28	M 36 x 2	75,0	31,0	15	14	68,5	38,5	55	60	46
DGS NW 32 HL	L	PN 160	35	M 45 x 2	74,0	31,5	15	16	68,5	42,0	55	60	55
DGS NW 04 HS H	S	PN 500	8	M 16 x 1,5	42,0	16,0	5	12	37,0	23,0	19	22	22
DGS NW 08 HS H	S	PN 500	12	M 20 x 1,5	52,5	15,5	5	12	48,0	23,0	24	30	27
DGS NW 13 HS H	S	PN 400	16	M 24 x 1,5	51,5	17,5	5	14	46,0	26,0	24	30	32
DGS NW 16 HS H	S	PN 400	20	M 30 x 2	65,5	28,5	15	16	60,0	39,0	36	41	41
DGS NW 20 HS H	S	PN 400	25	M 36 x 2	66,0	30,0	15	18	60,0	42,0	36	41	46
DGS NW 25 HS H	S	PN 400	30	M 42 x 2	75,5	30,5	15	22	69,0	44,0	55	60	50

Serie: LL = muy ligero L = ligero S = pesado - PN = presión nominal PB = presión de servicio máx. - Ø d2 = diámetro exterior del tubo