

Características

Conexión 1 - 3	Rosca exterior métrica, cilíndrica
Forma de obturación 1 - 3	Cono interior de 24°
Construcción	Racor
Forma constructiva	en T
Norma	DIN 2353 ISO 8434-1
Volumen de suministro	Tubuladura (sin tuerca de racor ni anillo cortante)
Material	Acero
Protección de la superficie	con revestimiento galvanizado

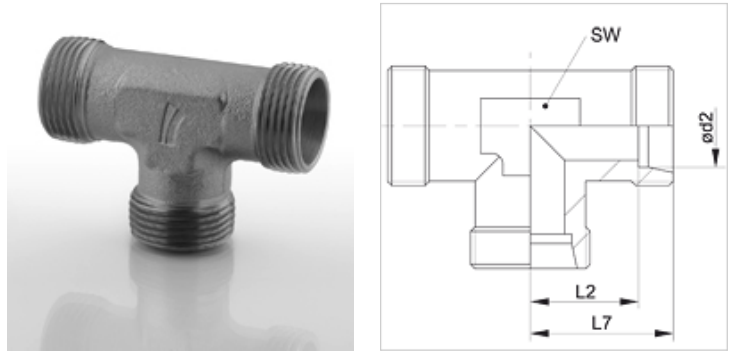

Nota

Para obtener información acerca del montaje, la instalación, la carga de presión y las temperaturas de servicio admisibles, consulte la Información técnica de los racores de tubo.

Artículo

Denominación	Serie	Presión de servicio en bar	Ø d2 (mm)	G1 - G3	L2 (mm)	L7 (mm)	SW (mm)
XT 04 LL	LL	PN 100	4	M 8 x 1	11,0	15	9
XT 05 LL	LL	PN 100	5	M 10 x 1	9,5	15	9
XT 06 LL	LL	PN 100	6	M 10 x 1	9,5	15	9
XT 08 LL	LL	PN 100	8	M 12 x 1	11,5	17	12
XT 10 LL	LL	PN 100	10	M 14 x 1	12,5	18	12
XT 12 LL	LL	PN 100	12	M 16 x 1	15,0	21	14
XT NW 04 HL	L	PN 315	6	M 12 x 1,5	12,0	19	12
XT NW 06 HL	L	PN 315	8	M 14 x 1,5	14,0	21	12
XT NW 08 HL	L	PN 315	10	M 16 x 1,5	15,0	22	14
XT NW 10 HL	L	PN 315	12	M 18 x 1,5	17,0	24	17
XT NW 13 HL	L	PN 315	15	M 22 x 1,5	21,0	28	19
XT NW 16 HL	L	PN 315	18	M 26 x 1,5	23,5	31	24
XT NW 20 HL	L	PN 160	22	M 30 x 2	27,5	35	27
XT NW 25 HL	L	PN 160	28	M 36 x 2	30,5	38	36
XT NW 32 HL	L	PN 160	35	M 45 x 2	34,5	45	41
XT NW 40 HL	L	PN 160	42	M 52 x 2	40,0	51	50
XT NW 03 HS	S	PN 630	6	M 14 x 1,5	16,0	23	12
XT NW 04 HS	S	PN 630	8	M 16 x 1,5	17,0	24	14
XT NW 06 HS	S	PN 630	10	M 18 x 1,5	17,5	25	17
XT NW 08 HS	S	PN 630	12	M 20 x 1,5	21,5	29	17
XT NW 10 HS	S	PN 630	14	M 22 x 1,5	22,0	30	19
XT NW 13 HS	S	PN 400	16	M 24 x 1,5	24,5	33	24
XT NW 16 HS	S	PN 400	20	M 30 x 2	26,5	37	27
XT NW 20 HS	S	PN 400	25	M 36 x 2	30,0	42	36
XT NW 25 HS	S	PN 400	30	M 42 x 2	35,5	49	41
XT NW 32 HS	S	PN 315	38	M 52 x 2	41,0	57	50

Serie: LL = muy ligero L = ligero S = pesado - PN = presión nominal PB = presión de servicio máx. - Ø d2 = diámetro exterior del tubo

Variantes de producto

XT VA	Racor, en T, Acero fino
T	Racor, en T, Acero