

Características

Conexión 1	Roscas exteriores BSP cilíndricas
Forma de obturación 1	Forma E
Conexión 2	Rosca exterior métrica, cilíndrica
Forma de obturación 2	Cono interior de 24°
Construcción	Racor de rosca macho
Forma constructiva	recto
Norma	DIN 2353 ISO 8434-1
Volumen de suministro	Tubuladura con tuerca de racor y anillo cortante
Material	Latón

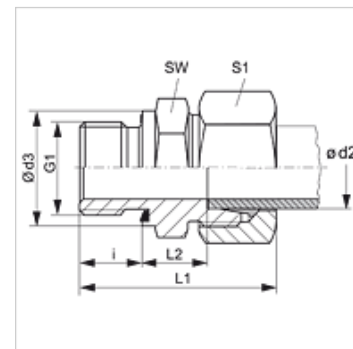

Nota

Para obtener información acerca del montaje, la instalación, la carga de presión y las temperaturas de servicio admisibles, consulte la Información técnica de los racores de tubo.

Artículo

Denominación	Serie	Presión de servicio en bar	Ø d2 (mm)	G1	Ø d3 (mm)	i (mm)	L1 (mm)	L2 (mm)	SW (mm)	S1
VR NW 04 HL ED MG	L	PN 200	6	G 1/8" -28	14,0	8	31,0	8,5	14	14
VR NW 06 HL ED MG	L	PN 200	8	G 1/4" -19	18,7	12	37,0	10,0	19	17
VR NW 10 HL ED MG	L	PN 200	12	G 3/8" -19	22,0	12	39,0	12,5	22	22
VR NW 13 HL ED MG	L	PN 200	15	G 1/2" -14	26,7	14	43,0	14,0	27	27
VR NW 16 HL ED MG	L	PN 200	18	G 1/2" -14	26,7	14	45,0	14,5	27	32
VR NW 20 HL ED MG	L	PN 100	22	G 3/4" -14	32,0	16	49,0	16,5	32	36
VR NW 25 HL ED MG	L	PN 100	28	G 1" -11	39,7	18	52,0	17,5	41	41
VR NW 32 HL ED MG	L	PN 200	35	G 1.1/4" -11	49,7	20	59,0	17,5	50	50
VR NW 40 HL ED MG	L	PN 200	42	G 1.1/2" -11	55,0	22	69,0	19,0	55	60
VR NW 03 HS ED MG	S	PN 400	6	G 1/4" -19	18,7	12	40,0	13,0	19	17
VR NW 04 HS ED MG	S	PN 400	8	G 1/4" -19	18,7	12	42,0	15,0	19	19
VR NW 06 HS ED MG	S	PN 400	10	G 3/8" -19	22,0	12	43,0	15,0	22	22
VR NW 08 HS ED MG	S	PN 400	12	G 3/8" -19	22,0	12	45,0	17,0	22	24
VR NW 13 HS ED MG	S	PN 250	16	G 1/2" -14	26,7	14	51,0	18,5	27	30
VR NW 16 HS ED MG	S	PN 250	20	G 3/4" -14	32,0	16	58,0	20,5	32	36
VR NW 20 HS ED MG	S	PN 250	25	G 1" -11	39,7	18	65,0	23,0	41	46
VR NW 25 HS ED MG	S	PN 250	30	G 1.1/4" -11	49,7	20	70,0	23,5	50	50

Serie: LL = muy ligero L = ligero S = pesado - PN = presión nominal PB = presión de servicio máx. - Ø d2 = diámetro exterior del tubo

Variantes de producto

VR ED	Racor de rosca macho, Acero
VR ED VA	Racor de rosca macho, Acero fino

Piezas de repuesto

WD	Junta blanda para racores ED
----	------------------------------