

Características

Conexión 1 + 2	Rosca exterior métrica, cilíndrica
Forma de obturación 1 + 2	Cono interior de 24°
Construcción	Racor de paso
Forma constructiva	recto
Norma	DIN 2353 ISO 8434-1
Volumen de suministro	Tubuladura (sin tuerca de racor ni anillo cortante)
Material	Acero fino

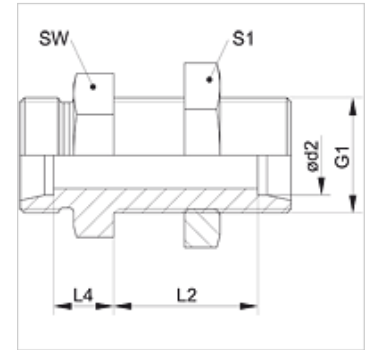

Nota

Para obtener información acerca del montaje, la instalación, la carga de presión y las temperaturas de servicio admisibles, consulte la Información técnica de los racores de tubo.

Artículo

Denominación	Serie	Presión de servicio en bar	Ø d2 (mm)	G1	L2 (mm)	L4 (mm)	SW (mm)	S1
XSV NW 04 HL VA	L	PN 315	6	M 12 x 1,5	27,0	7,0	17	17
XSV NW 06 HL VA	L	PN 315	8	M 14 x 1,5	27,0	8,0	19	19
XSV NW 08 HL VA	L	PN 315	10	M 16 x 1,5	28,0	10,0	22	22
XSV NW 10 HL VA	L	PN 315	12	M 18 x 1,5	29,0	10,0	24	24
XSV NW 13 HL VA	L	PN 315	15	M 22 x 1,5	31,0	12,0	27	30
XSV NW 16 HL VA	L	PN 315	18	M 26 x 1,5	32,5	13,5	32	36
XSV NW 20 HL VA	L	PN 160	22	M 30 x 2	34,5	16,5	36	41
XSV NW 25 HL VA	L	PN 160	28	M 36 x 2	35,5	18,5	41	46
XSV NW 32 HL VA	L	PN 160	35	M 45 x 2	36,5	18,5	50	55
XSV NW 40 HL VA	L	PN 160	42	M 52 x 2	36,0	19,0	60	65
XSV NW 03 HS VA	S	PN 630	6	M 14 x 1,5	29,0	12,0	19	19
XSV NW 04 HS VA	S	PN 630	8	M 16 x 1,5	29,0	13,0	22	22
XSV NW 06 HS VA	S	PN 630	10	M 18 x 1,5	29,5	14,5	24	24
XSV NW 08 HS VA	S	PN 630	12	M 20 x 1,5	30,5	14,5	27	27
XSV NW 10 HS VA	S	PN 630	14	M 22 x 1,5	32,0	17,0	30	30
XSV NW 13 HS VA	S	PN 400	16	M 24 x 1,5	31,5	16,5	32	32
XSV NW 16 HS VA	S	PN 400	20	M 30 x 2	33,5	17,5	41	41
XSV NW 20 HS VA	S	PN 400	25	M 36 x 2	35,0	20,0	46	46
XSV NW 25 HS VA	S	PN 400	30	M 42 x 2	37,5	21,5	50	50
XSV NW 32 HS VA	S	PN 315	38	M 52 x 2	37,0	22,0	65	65

Serie: LL = muy ligero L = ligero S = pesado - PN = presión nominal PB = presión de servicio máx. - Ø d2 = diámetro exterior del tubo

Variantes de producto

XSV	Racor de paso, Acero
SV VA	Racor de paso, Acero fino