

Características

Conexión 1 + 2	Rosca exterior métrica, cilíndrica
Forma de obturación 1 + 2	Cono interior de 24°
Construcción	Racor de paso
Forma constructiva	Ángulo de 90°
Norma	DIN 2353 ISO 8434-1
Volumen de suministro	Tubuladura (sin tuerca de racor ni anillo cortante)
Material	Acero
Protección de la superficie	con revestimiento galvanizado

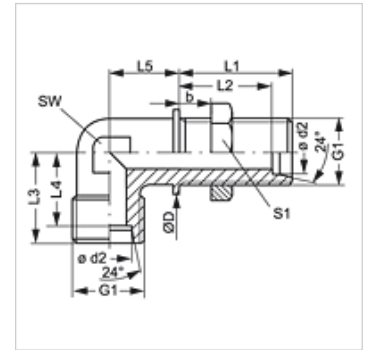

Nota

Para obtener información acerca del montaje, la instalación, la carga de presión y las temperaturas de servicio admisibles, consulte la Información técnica de los racores de tubo.

Artículo

Denominación	Serie	Presión de servicio en bar	Ø d2 (mm)	G1	Ø D (mm)	b (mm)	L1 (mm)	L2 (mm)	L3 (mm)	L4 (mm)	L5 (mm)	SW (mm)	S1
XSW NW 04 HL	L	PN 315	6	M 12 x 1,5	17	16	34	27,0	19	12,0	14	12	17
XSW NW 06 HL	L	PN 315	8	M 14 x 1,5	19	16	34	27,0	21	14,0	17	12	19
XSW NW 08 HL	L	PN 315	10	M 16 x 1,5	22	16	35	28,0	22	15,0	18	14	22
XSW NW 10 HL	L	PN 315	12	M 18 x 1,5	24	16	36	29,0	24	17,0	20	17	24
XSW NW 13 HL	L	PN 315	15	M 22 x 1,5	27	16	38	31,0	28	21,0	23	19	30
XSW NW 16 HL	L	PN 315	18	M 26 x 1,5	32	16	40	32,5	31	23,5	24	24	36
XSW NW 20 HL	L	PN 160	22	M 30 x 2	36	16	42	34,5	35	27,5	30	27	41
XSW NW 25 HL	L	PN 160	28	M 36 x 2	42	16	43	35,5	38	30,5	34	36	46
XSW NW 32 HL	L	PN 160	35	M 45 x 2	50	16	47	36,5	45	34,5	39	41	55
XSW NW 40 HL	L	PN 160	42	M 52 x 2	60	16	47	36,0	51	40,0	43	50	65
XSW NW 03 HS	S	PN 630	6	M 14 x 1,5	19	16	36	29,0	23	16,0	17	12	19
XSW NW 04 HS	S	PN 630	8	M 16 x 1,5	22	16	36	29,0	24	17,0	18	14	22
XSW NW 06 HS	S	PN 630	10	M 18 x 1,5	24	16	36	29,5	25	17,5	20	17	24
XSW NW 08 HS	S	PN 630	12	M 20 x 1,5	27	16	38	30,5	29	21,5	21	17	27
XSW NW 10 HS	S	PN 630	14	M 22 x 1,5	27	16	40	32,0	30	22,0	23	19	30
XSW NW 13 HS	S	PN 400	16	M 24 x 1,5	30	16	40	31,5	33	24,5	24	24	32
XSW NW 16 HS	S	PN 400	20	M 30 x 2	36	16	44	33,5	37	26,5	30	27	41
XSW NW 20 HS	S	PN 400	25	M 36 x 2	42	16	47	35,0	42	30,0	34	36	46
XSW NW 25 HS	S	PN 400	30	M 42 x 2	50	16	51	37,5	49	35,5	39	41	50
XSW NW 32 HS	S	PN 315	38	M 52 x 2	60	16	53	37,0	57	41,0	43	50	65

Serie: LL = muy ligero L = ligero S = pesado - PN = presión nominal PB = presión de servicio máx. - Ø d2 = diámetro exterior del tubo

Variantes de producto

XSW VA	Racor de paso, ángulo de 90°, Acero fino
SW	Racor de paso, ángulo de 90°, Acero