

XSW VA

Racor de paso, ángulo de 90°

HANSA FLEX

Características

Conexión 1 + 2	Rosca exterior métrica, cilíndrica
Forma de obturación 1 + 2	Cono interior de 24°
Construcción	Racor de paso
Forma constructiva	Ángulo de 90°
Norma	DIN 3911
Volumen de suministro	Tubuladura (sin tuerca de racor ni anillo cortante)
Material	Acero fino

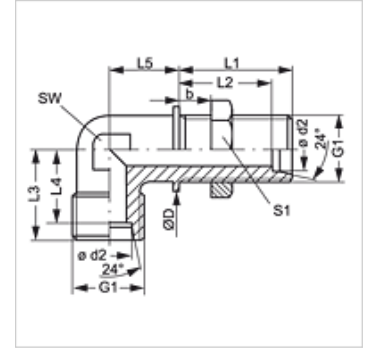

Nota

Para obtener información acerca del montaje, la instalación, la carga de presión y las temperaturas de servicio admisibles, consulte la Información técnica de los racores de tubo.

Artículo

Denominación	Serie	Presión de servicio en bar	Ø d2 (mm)	G1	Ø D (mm)	b (mm)	L1 (mm)	L2 (mm)	L3 (mm)	L4 (mm)	L5 (mm)	SW (mm)	S1
XSW NW 04 HL VA	L	PN 315	6	M 12 x 1,5	17	16	34	27,0	19	12,0	14	12	17
XSW NW 06 HL VA	L	PN 315	8	M 14 x 1,5	19	16	34	27,0	21	14,0	17	12	19
XSW NW 08 HL VA	L	PN 315	10	M 16 x 1,5	22	16	35	28,0	22	15,0	18	14	22
XSW NW 10 HL VA	L	PN 315	12	M 18 x 1,5	24	16	36	29,0	24	17,0	20	17	24
XSW NW 13 HL VA	L	PN 315	15	M 22 x 1,5	27	16	38	31,0	28	21,0	25	19	30
XSW NW 16 HL VA	L	PN 315	18	M 26 x 1,5	32	16	40	32,5	31	23,5	24	24	36
XSW NW 20 HL VA	L	PN 160	22	M 30 x 2	36	16	42	34,5	35	27,5	30	27	41
XSW NW 25 HL VA	L	PN 160	28	M 36 x 2	42	16	43	35,5	38	30,5	34	36	46
XSW NW 32 HL VA	L	PN 160	35	M 45 x 2	50	16	47	36,5	45	34,5	39	41	55
XSW NW 40 HL VA	L	PN 160	42	M 52 x 2	60	16	47	36,0	51	40,0	43	50	65
XSW NW 03 HS VA	S	PN 630	6	M 14 x 1,5	19	16	36	29,0	23	16,0	17	12	19
XSW NW 04 HS VA	S	PN 630	8	M 16 x 1,5	22	16	36	29,0	24	17,0	18	14	22
XSW NW 06 HS VA	S	PN 630	10	M 18 x 1,5	24	16	36	29,5	25	17,5	20	17	24
XSW NW 08 HS VA	S	PN 630	12	M 20 x 1,5	27	16	38	30,5	29	21,5	21	17	27
XSW NW 10 HS VA	S	PN 630	14	M 22 x 1,5	27	16	40	32,0	30	22,0	23	19	30
XSW NW 13 HS VA	S	PN 400	16	M 24 x 1,5	30	16	40	31,5	33	24,5	24	24	32
XSW NW 16 HS VA	S	PN 400	20	M 30 x 2	36	16	44	33,5	37	26,5	30	27	41
XSW NW 20 HS VA	S	PN 400	25	M 36 x 2	42	16	47	35,0	42	30,0	34	36	46
XSW NW 25 HS VA	S	PN 400	30	M 42 x 2	50	16	51	37,5	49	35,5	39	41	50
XSW NW 32 HS VA	S	PN 315	38	M 52 x 2	60	16	53	37,0	57	41,0	43	50	65

Serie: LL = muy ligero L = ligero S = pesado - PN = presión nominal PB = presión de servicio máx. - Ø d2 = diámetro exterior del tubo

Variantes de producto

XSW	Racor de paso, ángulo de 90°, Acero
SW VA	Racor de paso, ángulo de 90°, Acero fino