

Características

Conexión 1	Rosca exterior UN/UNF
Forma de obturación 1	Obturación por junta tórica en la tubuladura macho
Conexión 2	Rosca de tuerca NPSM
Forma de obturación 2	Cono exterior 60°
Construcción	Tubuladura macho
Forma constructiva	recto
Material	Acero
Protección de la superficie	con revestimiento galvanizado

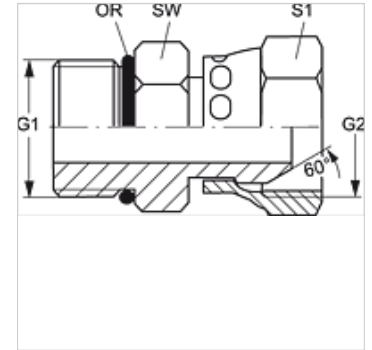

Artículo

Denominación	G1	G2	SW (mm)	S1	OR
GE O 04 AN	7/16" -20 UNF	1/4" -18 NPT	14	18	8,92 x 1,83
GE O 06 AN	9/16" -18 UNF	3/8" -18 NPT	18	22	11,90 x 1,98
GE O 06 AN 08	9/16" -18 UNF	1/2" -14 NPT	19	25	11,90 x 1,98
GE O 08 AN	3/4" -16 UNF	1/2" -14 NPT	22	25	16,36 x 2,20
GE O 08 AN 12	3/4" -16 UNF	3/4" -14 NPT	25	32	16,36 x 2,20
GE O 10 AN 06	7/8" -14 UNF	3/8" -18 NPT	22	25	19,18 x 2,46
GE O 10 AN 08	7/8" -14 UNF	1/2" -14 NPT	25	25	19,18 x 2,46
GE O 12 AN 08	1.1/16" -12 UN	1/2" -14 NPT	32	25	23,47 x 2,95
GE O 12 AN	1.1/16" -12 UN	3/4" -14 NPT	32	32	23,47 x 2,95
GE O 16 AN	1.5/16" -12 UN	1" -11,5 NPT	38	38	29,74 x 2,95

SW, S1, S2 = ancho de llave