

# PHN 200 VA

Engaste a presión para tubo flexible de malla

**HANSA FLEX**

## Características

**Clase de engaste** Engaste sin pelar

**apto para** 2SN (HD 200)  
3TE (TE 300)

**Material** Acero fino

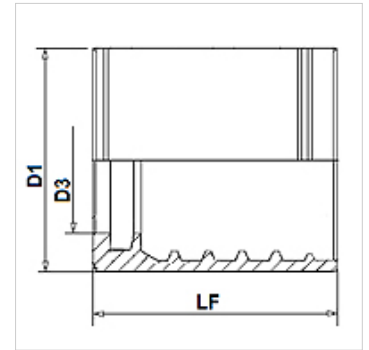
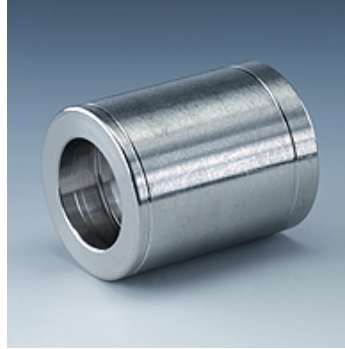

## Nota

La asignación del engaste depende del tipo de tubo flexible.

## Artículo

Denominación	DN*	Tamaño	Pulgadas	D1 (mm)	D3 (mm)	LF (mm)
PHN 206 VA	6	4	1/4"	22,0	10,3	34,5
PHN 208 VA	8	5	5/16"	24,0	12,0	34,5
PHN 210 VA	10	6	3/8"	26,0	14,0	35,0
PHN 213 VA	12	8	1/2"	30,0	17,2	37,0
PHN 216 VA	16	10	5/8"	33,0	20,2	40,0
PHN 220 VA	19	12	3/4"	38,0	24,2	45,0
PHN 225 VA	25	16	1"	46,0	31,5	50,0

DN = diámetro nominal, ancho nominal