

# TR G VB

Conector para tubo Tecalan

**HANSA FLEX**

## Características

|                             |                        |
|-----------------------------|------------------------|
| Forma constructiva          | recto                  |
| Construcción                | Conectores insertables |
| Material                    | Latón                  |
| Protección de la superficie | niquelado              |

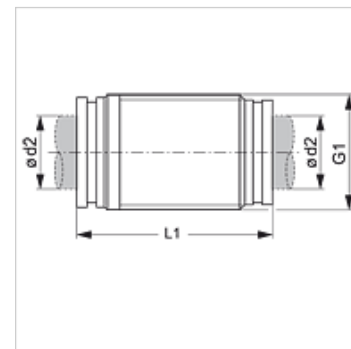

## Artículo

| Denominación | Ø d2<br>(mm) | G1       | L1<br>(mm) |
|--------------|--------------|----------|------------|
| TR 04 G VB   | 4            | M 11 x 1 | 28,6       |
| TR 05 G VB   | 5            | M 14 x 1 | 33,5       |
| TR 06 G VB   | 6            | M 13 x 1 | 31,2       |
| TR 08 G VB   | 8            | M 15 x 1 | 33,9       |
| TR 10 G VB   | 10           | M 17 x 1 | 37,8       |
| TR 12 G VB   | 12           | M 20 x 1 | 39,7       |
| TR 14 G VB   | 14           | M 24 x 1 | 45,5       |