

### Características

**Material** NBR

**Utilización** para motores eléc. forma IM B35

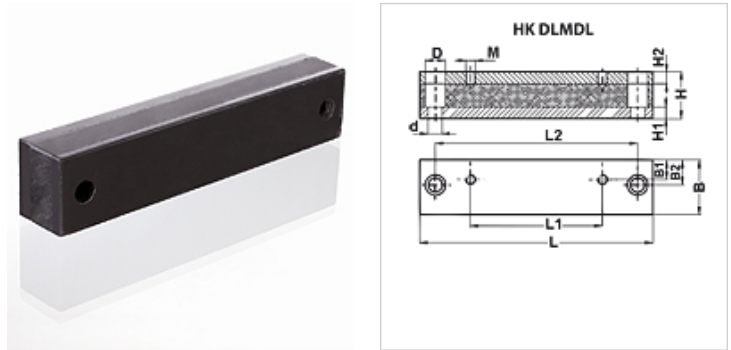

### Descripción

para disminución del nivel de ruido y amortiguación de vibraciones  
 goma natural amortiguadora con guías vulcanizadas  
 ninguna unión metálica entre estructura e infraestructura

### Artículo

Denominación	IEC motor tamaño constructivo	B (mm)	B1 (mm)	B2 (mm)	D (mm)	d (mm)	H (mm)	H1 (mm)	H2 (mm)	L (mm)	L1 (mm)	L2 (mm)	M	Peso (kg)
HK DLMDL 90L	90L	50,00	22,0	25,0	20,0	14,00	40,0	8,00	12	240,0	125,0	205,0	M8	2,10
HK DLMDL 100L	100L	50,00	24,0	25,0	20,0	14,00	40,0	8,00	12	240,0	140,0	205,0	M10	2,25
HK DLMDL 112M	112M	50,00	20,0	25,0	20,0	14,00	40,0	8,00	12	240,0	140,0	205,0	M10	2,30
HK DLMDL 132S	132S	50,00	20,0	25,0	20,0	14,00	45,0	8,00	12	285,0	140,0	245,0	M10	2,42
HK DLMDL 132M	132M	50,00	20,0	25,0	20,0	14,00	45,0	8,00	12	285,0	178,0	245,0	M10	2,42
HK DLMDL 160M	160M	70,00	28,0	35,0	26,0	18,00	60,0	15,00	15	340,0	210,0	300,0	M12	7,50
HK DLMDL 160L	160L	70,00	28,0	35,0	26,0	18,00	60,0	15,00	15	416,0	254,0	370,0	M12	7,50
HK DLMDL 180M	180M	70,00	35,0	35,0	26,0	18,00	60,0	15,00	15	416,0	241,0	370,0	M12	8,00
HK DLMDL 180L	180L	70,00	35,0	35,0	26,0	18,00	60,0	15,00	15	446,0	279,0	400,0	M12	8,00
HK DLMDL 200L	200L	70,00	35,0	35,0	32,0	22,00	60,0	15,00	15	496,0	305,0	430,0	M16	8,55