

VFR (1,0 mm)

Anillo de obturación de fibra vulcanizada, de 1 mm de espesor

HANSA FLEX

Características

Norma DIN 7603-A

Material Fibra vulcanizada

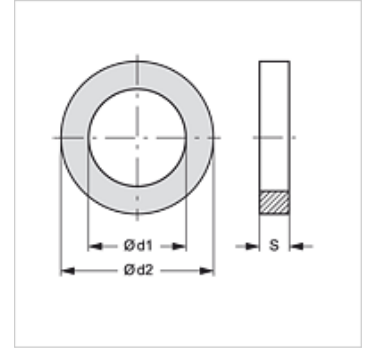

Artículo

Denominación	d1 (mm)	d2 (mm)	S (mm)
VFR 4-8-1	4,00	8,00	1,00
VFR 5-9-1	5,00	9,00	1,00
VFR 6-10-1	6,00	10,00	1,00
VFR 8-12-1	8,00	12,00	1,00
VFR 8-14-1	8,00	14,00	1,00
VFR 10-14-1	10,00	14,00	1,00
VFR 10-16-1	10,00	16,00	1,00
VFR 13-18-1	13,00	18,00	1,00