

Características

Construcción	Extractor
Velocidad de deslizamiento max.	0,8 m/s
Temperatura min.	-30 °C
Temperatura max.	110 °C
Medios	Aceites minerales Emulsiones de agua
Montaje	Dar forma de riñón e introducir en la ranura de admisión
Material	Poliéster
Aplicación	Hidráulica

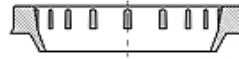

Toleranz / Tolerance			
d	D	L	C
h11	+0,20 0	+0,10 0	+0,20 0

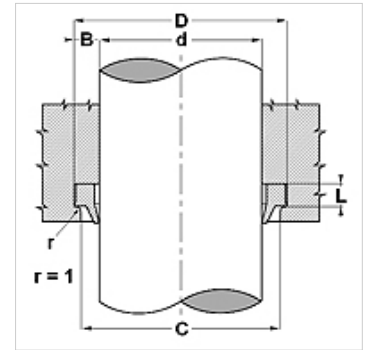

Descripción

Solución sencilla.
montaje sencillo.
elevada resistencia a la abrasión

Artículo

Denominación	d (mm)	D (mm)	L (mm)	C (mm)
WRM-H 20	20	28	5,0	25,5
WRM-H 25	25	33	5,0	30,5
WRM-H 28	28	36	5,0	33,5
WRM-H 30	30	38	5,0	35,5
WRM-H 32	32	40	5,0	37,5
WRM-H 36	36	44	5,0	41,5
WRM-H 40	40	48	5,0	45,5
WRM-H 45	45	53	5,0	50,5
WRM-H 50	50	58	5,0	55,5
WRM-H 60	60	70	6,3	67,0
WRM-H 70	70	80	6,3	77,0
WRM-H 80	80	90	6,3	87,0
WRM-H 90	90	100	6,3	97,0
WRM-H 100	100	115	9,5	110,0
WRM-H 110	110	125	9,5	120,0
WRM-H 125	125	140	9,5	135,0