

HK B5 400/690V IE3

Motor eléctrico B5 400/690 V IE3

HANSA FLEX

Características

| | |
|-------------------------|--|
| Versión | Forma constructiva B5 sin pies |
| Tipo de protecc. | IP 55 |
| Temp. entorno | -20 °C hasta +40 °C |
| Material | Carcasa: Aluminio Housing: Grey cast iron (from HK180L4***) |

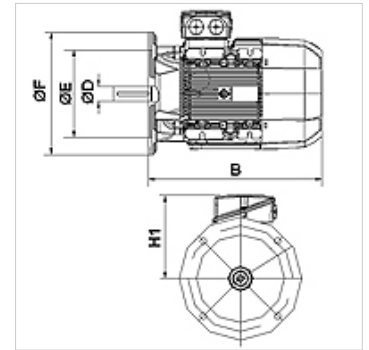

Descripción

Motores jaula de ardilla auto refrigerados de ahorro energético
High Efficiency IE3 - IEC60034-30:2009
Tensión de medición 400/690V 50Hz, 460V 60Hz; 4 polos
Tolerancia de tensión +- 5%
desde 11kW incl. Protección térmica (resistencia PTC)

Artículo

| Denominación | n 50 Hz (rpm) | n 60 Hz (rpm) | P 50 Hz (kW) | P 60 Hz (kW) | I 50 Hz (A) | LF 50 Hz | H1 (mm) | B (mm) | Ø D eje (mm) | Ø E (mm) | Ø F (mm) | η (IE3) % | Peso (kg) |
|----------------------|------------------|------------------|-----------------|-----------------|----------------|----------|------------|-----------|-----------------|-------------|-------------|-----------|--------------|
| HK 112M4 B5 4-6 IE3 | 1440 | 1728 | 4,00 | 4,60 | 14,00 | 0,80 | 180 | 340 | 28 | 180 | 250 | 88,6 | 37,5 |
| HK 132SB4 B5 4-6 IE3 | 1460 | 1752 | 5,50 | 6,30 | 11,10 | 0,80 | 190 | 388 | 38 | 230 | 300 | 89,6 | 49,5 |
| HK 132M4 B5 4-6 IE3 | 1470 | 1770 | 7,50 | 8,60 | 14,30 | 0,84 | 225 | 453 | 38 | 230 | 300 | 90,4 | 48,0 |
| HK 160M4 B5 4-6 IE3 | 1470 | 1770 | 11,00 | 12,60 | 20,60 | 0,84 | 260 | 545 | 42 | 250 | 350 | 91,4 | 125,0 |
| HK 160L4 B5 4-6 IE3 | 1470 | 1770 | 15,00 | 17,30 | 27,60 | 0,86 | 260 | 604 | 42 | 250 | 350 | 92,1 | 82,0 |
| HK 180M4 B5 4-6 IE3 | 1475 | 1775 | 18,50 | 21,30 | 33,80 | 0,86 | 280 | 628 | 48 | 250 | 350 | 92,6 | 159,0 |
| HK 180L4 B5 4-6 IE3 | 1475 | 1775 | 22,00 | 25,30 | 40,00 | 0,86 | 280 | 668 | 48 | 250 | 350 | 93,0 | 184,0 |
| HK 200L4 B5 4-6 IE3 | 1475 | 1775 | 30,00 | 34,50 | 54,30 | 0,86 | 305 | 660 | 55 | 300 | 400 | 93,6 | 224,0 |
| HK 225S4 B5 4-6 IE3 | 1480 | 1780 | 37,00 | 42,50 | 66,70 | 0,86 | 335 | 680 | 60 | 350 | 450 | 93,9 | 284,0 |
| HK 225M4 B5 4-6 IE3 | 1480 | 1780 | 45,00 | 52,00 | 80,90 | 0,86 | 335 | 705 | 60 | 350 | 450 | 94,2 | 314,0 |
| HK 250M4 B5 4-6 IE3 | 1480 | 1780 | 55,00 | 63,00 | 98,40 | 0,86 | 370 | 770 | 60 | 450 | 550 | 94,6 | 390,0 |

P 50 Hz = nominal output at 400 V/50 Hz - P 60 Hz = potencia nominal en 400 V/60 Hz - n 50 Hz = velocidad nominal en 400 V/50 Hz - n 60 Hz = velocidad nominal en 400 V/60 Hz - I 50 Hz = intensidad nominal en 400 V/50 Hz - LF 50 Hz = factor de potencia cos phi en 50 Hz - η (IE3) = efficiency to IE3 in % (at full load)