

# K-ELEKTRO-KABELAUFROLL POLY

Electrical cable reel (polypropylene) easy mounting on the wall or ceiling

**HANSA FLEX**

## Características

|                     |  |
|---------------------|--|
| Tipo de cable       | HO5VV-F  |
| Intensidad corr.    | Max. 10 A  |
| Conexión            | SchuKo plug  |
| para tensión        | 230 V, 50 Hz   |
| Consumo de potencia | Max. 1000 W (fully wound), max. 2000 W (fully unwound) |
| Ángulo de giro      | 180°   |

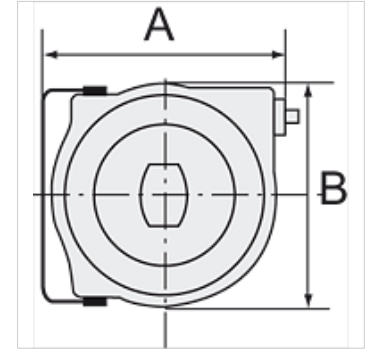

## Nota

Otras especificaciones a petición.

## Descripción

High-quality, polypropylene housing. Includes a thermal circuit breaker. In case of overloading, a thermal overload protective circuit cuts off the electrical power supply automatically.

## Artículo

| Denominación   | A<br>(mm) | B<br>(mm) | Longitud<br>(m) |
|----------------|-----------|-----------|-----------------|
| K- 07 10 03 48 | 335,0     | 290,0     | 15              |