

K-SSV VA

Angle-seat valves with piston actuator

HANSA FLEX

Características

Pres. diferencial	0 - 16 bar
Temper. de medios	-10 °C to +180 °C
Conex. aire de mando	G 1/8
Temp. medio de control	max. +60 °C
Temp. entorno	-20 °C to +70 °C
Presión estática admis.	Max. 16 bar
Carcasa válv	Stainless steel AISI 316
Pieza de unión	Stainless steel
Cabezal de control	Polyamide (glass fibre-reinforced)
Pistón	Nickel-plated brass (DN 15 to DN 32), PBT + GF 30% (DN 40 to DN 50)
Husillo	Stainless steel
Material obturador	PTFE

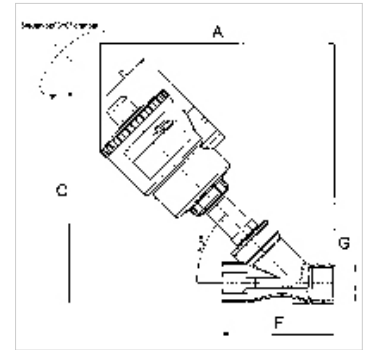

Nota

G thread acc. to DIN EN ISO 228-1, with ISO flange plate (acc. to ISO 5211)

For use on devices that have to be vented whenever they are turned off, either because of safety regulations or for technical reasons. The pneumatic devices are disconnected from the system and simultaneously vented each time they are shut off.

Otras especificaciones a petición.

Descripción

Angle-seat valves with external pilot control and a self-aligning valve disc for neutral (bronze body) or corrosive (stainless steel body) media. Very high flow due to angled seat design, Water hammer prevented by fluid entry under the disc, Suitable for vacuum operation (low vacuum), NAMUR interface on the piston actuator. 3/2 and 5/2-way valves can be mounted directly.

Información adicional

Other versions e.g. for steam on request

Information on max. operating differential pressures apply for air, gas, corrosive aggressive media, water

Artículo

Denominación	A (mm)	C (mm)	F (mm)	Rosca	Diferencia presión máx. de servicio (bar)	Presión mín. de mando	Presión máx. de mando
K- 07 30 25 33	190,0	169,0	85,0	G 1/2	16	4	10
K- 07 30 25 34	195,0	176,0	95,0	G 3/4	10	4	10
K- 07 30 25 35	213,0	195,0	95,0	G 3/4	16	4	10
K- 07 30 25 36	219,0	202,0	105,0	G 1	11	4	10