

# K-DVST OHNE REGLER

Pressure booster without regulator

**HANSA FLEX**

## Características

<b>Presión de entrada</b>	2 - 10 bar
<b>Presión inicial</b>	Max. 20 bar (regulated: max. 16 bar)
<b>Rango de temperatura</b>	-10 °C to +50 °C (40 mm bore), -10 °C to +60 °C (63 mm bore)
<b>Medios</b>	Filtered, unlubricated or lubricated compressed air (if lubrication is used, it must be continuous)
<b>Material obturador</b>	NBR
<b>Regulador de pres.</b>	With plastic body
<b>Carcasa</b>	Aluminium, anodised
<b>Tubo</b>	Anodised aluminium jacket
<b>Montaje</b>	Any position, with 4 mounting holes
<b>P2:P1</b>	2:1

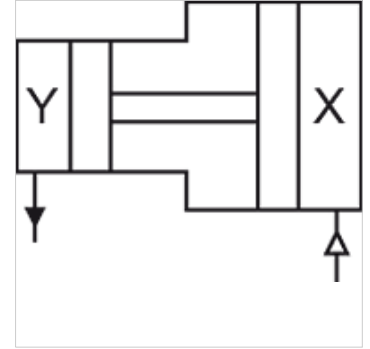

## Nota

For information about calculating the filling times for different tank sizes, refer to the above-mentioned data sheet available on our website  
Otras especificaciones a petición.

## Descripción

Pressure multipliers (boosters) allow a separate compressed air store with up to double pressure to be installed for selected devices in a compressed air system without an external energy source, i.e. it is possible to work with a maximum pressure of 20 bar in a standard 10 bar system (maximum ratio 2:1). This is achieved using a double piston, which is operated by a combination of integrated check valves in such a way that the booster works automatically until the target pressure is reached in a compressed air tank and is then automatically switched off. A tank is always required to build up the pressure and store the compressed air!

## Información adicional

Fixing bracket with nut

## Artículo

Denominación	Conexión	Ø pistón (mm)	H (mm)	L (mm)
K- 07 25 08 64	G 1/8	40,0	64,0	194,0
K- 07 25 08 66	G 3/8	63,0	98,0	290,0

## Accesorios

K-ZUBEH ERSATZ LUFT BOOSTER Accessories / spare parts for Air-air-multiplier (booster)