

K-ROHRFLANSCH DICHT INFI

Seal for pipe flange

HANSA FLEX

Características

Material NBR
Carbon fiber

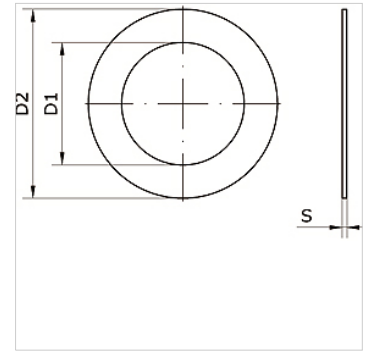

Artículo

Denominación	para Ø exterior tubo mm	D1 (mm)	D2 (mm)	S (mm)
K- 07 40 55 12	80	89,0	131	2
K- 07 40 54 59	110	105,0	162	2