

Omadused

Ühendus 1	Meetriline väliskeere, silindriline
Tihenditüüp 1	E-vorm
Ühendus 2	M-keere välis, silindriline
Tihenditüüp 2	24° sisekoonus
Tüüp	Pöörlev liitmik (sissekeeratav liitmik)
Lisa	Liuglaager
Ehitustüüp	Sirge
Komplektis	Liitmik (ilma mutri ja lõikurrõngata)
Materjal	Teras
Pinnatöötlus	galvaniseeritud

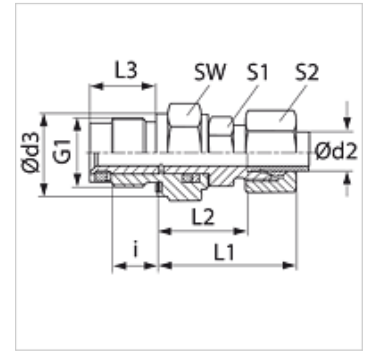

Vihje

Viiteid monteerimise, paigaldamise, survetugevuse ja lubatud töötemperatuuride kohta leiate toruühenduste tehnilisest juhendist.

Artikkel

Märgistus	Ehitusseeria	Töörõhk bar	Ø d2 (mm)	G1	i (mm)	Ø d3 (mm)	L1 (mm)	L2 (mm)	L3 (mm)	SW (mm)	S1	S2
GVM NW 04 HL 14	L	PN 40	6	M 14 x 1,5	12	19	27	20,0	18,0	19	12	14
GVM NW 06 HL 14	L	PN 40	8	M 14 x 1,5	12	19	29	21,0	18,0	19	12	17
GVM NW 08 HL 18	L	PN 40	10	M 18 x 1,5	12	24	30	26,0	18,0	24	14	19
GVM NW 10 HL 22	L	PN 40	12	M 22 x 1,5	14	27	32	27,0	21,0	27	17	22
GVM NW 13 HL 27	L	PN 40	15	M 27 x 2	16	32	36	33,0	24,0	32	19	27
GVM NW 16 HL 33	L	PN 40	18	M 33 x 2	18	40	40	37,5	27,5	41	27	32
GVM NW 20 HL 33	L	PN 40	22	M 33 x 2	18	40	44	39,5	27,5	41	27	36
GVM NW 25 HL 42	L	PN 40	28	M 42 x 2	20	50	47	44,0	31,0	50	36	41
GVM NW 32 HL 48	L	PN 40	35	M 48 x 2	22	55	56	54,0	35,0	55	41	50
GVM NW 03 HS 14	S	PN 100	6	M 14 x 1,5	12	19	31	21,0	18,0	19	12	17
GVM NW 04 HS	S	PN 100	8	M 14 x 1,5	12	19	32	22,0	18,0	19	14	19
GVM NW 06 HS 18	S	PN 100	10	M 18 x 1,5	12	24	34	27,0	18,0	24	17	22
GVM NW 08 HS	S	PN 100	12	M 22 x 1,5	14	27	38	28,0	21,0	27	17	24
GVM NW 13 HS 27	S	PN 100	16	M 27 x 2	16	32	43	34,0	24,0	32	24	30
GVM NW 16 HS 33	S	PN 100	20	M 33 x 2	18	40	48	39,5	27,5	41	27	36
GVM NW 20 HS	S	PN 100	25	M 33 x 2	18	40	54	42,5	27,5	41	36	46
GVM NW 25 HS	S	PN 100	30	M 42 x 2	20	50	62	48,0	31,0	50	41	50
GVM NW 32 HS	S	PN 100	38	M 48 x 2	22	55	72	55,0	35,0	55	50	60

Ehitusseeria: LL = väga kerge L = kerge S = raske – PN = nimirõhk PB = maks. töörõhk – Ø d2 = toru välisläbimõõt