

## Omadused

Ühendus 1	Meetriline mutrikeere
Tihenditüüp 1	O-rõngaga 24° väliskoonus
Ühendus 2 + 3	M-keere välis, silindriline
Tihenditüüp 2 + 3	24° sisekoonus
Tüüp	Suunatav liitmik
Ehitustüüp	T-kujuline
Tavaline	ISO 8434-4
Komplektis	Torumutri ja lõikurrõngaga liitmik
Materjal	Teras
Pinnatöötlus	galvaniseeritud

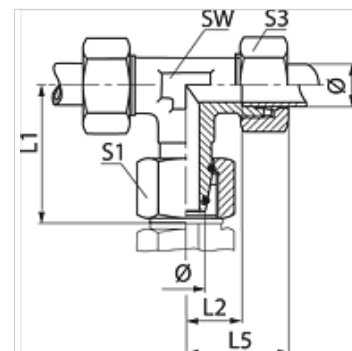

## Vihje

Viiteid monteerimise, paigaldamise, survetugevuse ja lubatud töötemperatuuride kohta leiate toruühenduste tehnilisest juhendist.

## Artikkel

Märgistus	Ehitusseeria	Töörõhk bar	Ø d2 (mm)	L1 (mm)	L2 (mm)	L5 (mm)	SW (mm)	S1	S3	OR
VETO NW 04 HL	L	PN 315	6	26,0	12,0	27	12	14	14	4,0 x 1,5
VETO NW 06 HL	L	PN 315	8	27,5	14,0	29	12	17	17	6,0 x 1,5
VETO NW 08 HL	L	PN 315	10	29,0	15,0	30	14	19	19	7,5 x 1,5
VETO NW 10 HL	L	PN 315	12	29,5	17,0	32	17	22	22	9,0 x 1,5
VETO NW 13 HL	L	PN 315	15	32,5	21,0	36	19	27	27	12,0 x 2,0
VETO NW 16 HL	L	PN 315	18	35,5	23,5	40	24	32	32	15,0 x 2,0
VETO NW 20 HL	L	PN 160	22	38,5	27,5	44	27	36	36	20,0 x 2,0
VETO NW 25 HL	L	PN 160	28	41,5	30,5	47	36	41	41	26,0 x 2,0
VETO NW 32 HL	L	PN 160	35	51,0	34,5	56	41	50	50	32,0 x 2,5
VETO NW 40 HL	L	PN 160	42	56,0	40,0	63	50	60	60	38,0 x 2,5
VETO NW 03 HS	S	PN 630	6	27,0	16,0	31	12	17	17	4,0 x 1,5
VETO NW 04 HS	S	PN 630	8	27,5	17,0	32	14	19	19	6,0 x 1,5
VETO NW 06 HS	S	PN 630	10	30,0	17,5	34	17	22	22	7,5 x 1,5
VETO NW 08 HS	S	PN 630	12	31,0	21,5	38	17	24	24	9,0 x 1,5
VETO NW 10 HS	S	PN 630	14	35,0	22,0	40	19	27	27	10,0 x 2,0
VETO NW 13 HS	S	PN 400	16	36,5	24,5	43	24	30	30	12,0 x 2,0
VETO NW 16 HS	S	PN 400	20	44,5	26,5	48	27	36	36	16,3 x 2,4
VETO NW 20 HS	S	PN 400	25	50,0	30,0	54	36	46	46	20,3 x 2,4
VETO NW 25 HS	S	PN 400	30	55,0	35,5	62	41	50	50	25,3 x 2,4
VETO NW 32 HS	S	PN 315	38	63,0	41,0	72	50	60	60	33,3 x 2,4

Ehitusseeria: LL = väga kerge L = kerge S = raske – PN = nimirõhk PB = maks. tööõhk – Ø = toru välisläbimõõt

## Toote variandid

VETO VA	Ühendus, T-kujuline, Roostevaba teras
XVETO	Ühendus, T-kujuline, Teras