

### Omadused

Ühendus 1	BSP-väliskeere, silindriline
Tihenditüüp 1	E-vorm
Ühendus 2	M-keere välis, silindriline
Tihenditüüp 2	24° sisekoonus
Tüüp	Sissekeeratav liitmik .
Ehitustüüp	Sirge
Tavaline	DIN 2353 ISO 8434-1
Komplektis	Torumutri ja lõikurrõngaga liitmik
Materjal	Messing

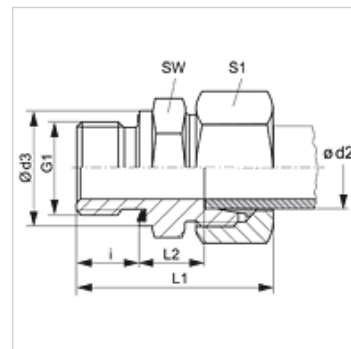

### Vihje

Viiteid monteerimise, paigaldamise, survetugevuse ja lubatud töötemperatuuride kohta leiata toruühenduste tehnilisest juhendist.

### Artikkel

Märgistus	Ehitusseeria	Töörõhk bar	Ø d2 (mm)	G1	Ø d3 (mm)	i (mm)	L1 (mm)	L2 (mm)	SW (mm)	S1
VR NW 04 HL ED MG	L	PN 200	6	G 1/8" -28	14,0	8	31,0	8,5	14	14
VR NW 06 HL ED MG	L	PN 200	8	G 1/4" -19	18,7	12	37,0	10,0	19	17
VR NW 10 HL ED MG	L	PN 200	12	G 3/8" -19	22,0	12	39,0	12,5	22	22
VR NW 13 HL ED MG	L	PN 200	15	G 1/2" -14	26,7	14	43,0	14,0	27	27
VR NW 16 HL ED MG	L	PN 200	18	G 1/2" -14	26,7	14	45,0	14,5	27	32
VR NW 20 HL ED MG	L	PN 100	22	G 3/4" -14	32,0	16	49,0	16,5	32	36
VR NW 25 HL ED MG	L	PN 100	28	G 1" -11	39,7	18	52,0	17,5	41	41
VR NW 32 HL ED MG	L	PN 200	35	G 1.1/4" -11	49,7	20	59,0	17,5	50	50
VR NW 40 HL ED MG	L	PN 200	42	G 1.1/2" -11	55,0	22	69,0	19,0	55	60
VR NW 03 HS ED MG	S	PN 400	6	G 1/4" -19	18,7	12	40,0	13,0	19	17
VR NW 04 HS ED MG	S	PN 400	8	G 1/4" -19	18,7	12	42,0	15,0	19	19
VR NW 06 HS ED MG	S	PN 400	10	G 3/8" -19	22,0	12	43,0	15,0	22	22
VR NW 08 HS ED MG	S	PN 400	12	G 3/8" -19	22,0	12	45,0	17,0	22	24
VR NW 13 HS ED MG	S	PN 250	16	G 1/2" -14	26,7	14	51,0	18,5	27	30
VR NW 16 HS ED MG	S	PN 250	20	G 3/4" -14	32,0	16	58,0	20,5	32	36
VR NW 20 HS ED MG	S	PN 250	25	G 1" -11	39,7	18	65,0	23,0	41	46
VR NW 25 HS ED MG	S	PN 250	30	G 1.1/4" -11	49,7	20	70,0	23,5	50	50

Ehitusseeria: LL = väga kerge L = kerge S = raske - PN = nimirõhk PB = maks. töörõhk - Ø d2 = toru välisläbimõõt

### Toote variandid

VR ED	Sissekeeratav liitmik, Teras
VR ED VA	Sissekeeratav ühendus, Roostevaba teras

### Varuosad

WD	Pehme tihend ED-liitmikule
----	----------------------------