

GVR 90

Pöörlev liitmik, W90°, liuglaager

HANSA FLEX

Omadused

Ühendus 1	BSP-väliskeere, silindriline
Tihenditüüp 1	E-vorm
Ühendus 2	M-keere välis, silindriline
Tihenditüüp 2	24° sisekoonus
Tüüp	Pöörlev liitmik (sissekeeratav liitmik)
Lisa	Liuglaager
Ehitustüüp	Nurk 90°
Komplektis	Liitmik (ilma mutri ja lõikurrõngata)
Materjal	Teras
Pinnatöötlus	galvaniseeritud

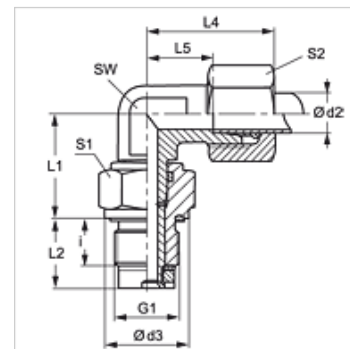

Vihje

Viiteid monteerimise, paigaldamise, survetugevuse ja lubatud töötemperatuuride kohta leiate toruühenduste tehnilisest juhendist.

Artikkel

Märgistus	Ehitusseeria	Töörõhk bar	Ø d2 (mm)	G1	d3 (mm)	i (mm)	L1 (mm)	L2 (mm)	L4 (mm)	L5 (mm)	SW (mm)	S1	S2
GVR 90 NW 04 HL 1/4	L	PN 40	6	G 1/4" -19	19	12	20,0	18,0	27	12,0	12	19	14
GVR 90 NW 06 HL	L	PN 40	8	G 1/4" -19	19	12	21,0	18,0	29	14,0	12	19	17
GVR 90 NW 08 HL 3/8	L	PN 40	10	G 3/8" -19	22	12	26,0	18,0	30	15,0	14	24	19
GVR 90 NW 10 HL 1/2	L	PN 40	12	G 1/2" -14	27	14	27,0	21,0	32	17,0	17	27	22
GVR 90 NW 13 HL 3/4	L	PN 40	15	G 3/4" -14	32	16	33,0	24,0	36	21,0	19	32	27
GVR 90 NW 16 HL 1	L	PN 40	18	G 1" -11	40	18	37,5	27,5	40	23,5	27	41	32
GVR 90 NW 20 HL 1	L	PN 40	22	G 1" -11	40	18	39,5	27,5	44	27,5	27	41	36
GVR 90 NW 25 HL 1 1/4	L	PN 40	28	G 1.1/4" -11	50	20	44,0	31,0	47	30,5	36	50	41
GVR 90 NW 32 HL 1 1/2	L	PN 40	35	G 1.1/2" -11	55	22	54,0	35,0	56	34,5	41	55	50
GVR 90 NW 03 HS	S	PN 100	6	G 1/4" -19	19	12	21,0	18,0	31	16,0	12	19	17
GVR 90 NW 04 HS	S	PN 100	8	G 1/4" -19	19	12	22,0	18,0	32	17,0	14	19	19
GVR 90 NW 06 HS	S	PN 100	10	G 3/8" -19	22	12	27,0	18,0	34	17,5	17	24	22
GVR 90 NW 08 HS 1/2	S	PN 100	12	G 1/2" -14	27	14	28,0	21,0	38	21,5	17	27	24
GVR 90 NW 13 HS 3/4	S	PN 100	16	G 3/4" -14	32	16	34,0	24,0	43	24,5	24	32	30
GVR 90 NW 16 HS 1	S	PN 100	20	G 1" -11	40	18	39,5	27,5	48	26,5	27	41	36
GVR 90 NW 20 HS	S	PN 100	25	G 1" -11	40	18	42,5	27,5	54	30,0	36	41	46
GVR 90 NW 25 HS	S	PN 100	30	G 1.1/4" -11	50	20	48,0	31,0	62	35,5	41	50	50
GVR 90 NW 32 HS	S	PN 100	38	G 1.1/2" -11	55	22	55,0	35,0	72	41,0	50	55	60

Ehitusseeria: LL = väga kerge L = kerge S = raske – PN = nimirõhk PB = maks. töörõhk – Ø d2 = toru välisläbimõõt