

### Omadused

Ühendus 1	BSPT-väliskeere, kooniline
Tihenditüüp 1	Keermestihend
Ühendus 2	M-keere välis, silindriline
Tihenditüüp 2	24° sisekoonus
Tüüp	Sissekeeratav liitmik .
Ehitustüüp	Nurk 90°
Tavaline	DIN 2353 ISO 8434-1
Komplektis	Torumutri ja lõikurrõngaga liitmik
Materjal	Teras
Pinnatöötlus	galvaniseeritud

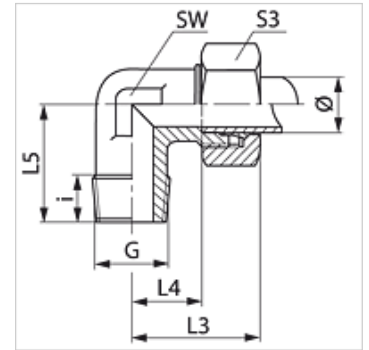

### Vihje

Viiteid monteerimise, paigaldamise, survetugevuse ja lubatud töötemperatuuride kohta leiate toruühenduste tehnilisest juhendist.

### Artikkel

Märgistus	Ehitusseeria	Töörõhk bar	Toru välimine Ø (mm)	G	i (mm)	L3 (mm)	L4 (mm)	L5 (mm)	SW (mm)	S3
WR 04 LL	LL	PN 100	4	R 1/8" K	8	21	11,0	18	11	10
WR 05 LL	LL	PN 100	5	R 1/8" K	8	22	10,0	17	11	12
WR 06 LL	LL	PN 100	6	R 1/8" K	8	22	10,0	17	11	12
WR 08 LL	LL	PN 100	8	R 1/8" K	8	23	11,5	20	12	14
WR 10 LL	LL	PN 100	10	R 1/4" K	12	27	15,5	26	14	17
WR 12 LL	LL	PN 100	12	R 1/4" K	12	27	15,0	27	17	19
WR NW 04 HL	L	PN 315	6	R 1/8" K	8	27	12,0	20	12	14
WR NW 04 HL 1/4	L	PN 315	6	R 1/4" K	12	29	14,0	26	12	14
WR NW 04 HL 3/8	L	PN 315	6	R 3/8" K	12	29	14,0	26	12	14
WR NW 06 HL 1/8	L	PN 315	8	R 1/8" K	8	29	14,0	26	12	17
WR NW 06 HL	L	PN 315	8	R 1/4" K	12	29	14,0	26	12	17
WR NW 06 HL 3/8	L	PN 315	8	R 3/8" K	12	34	19,0	28	17	17
WR NW 06 HL 1/2	L	PN 315	8	R 1/2" K	13	34	19,0	30	17	17
WR NW 08 HL 1/8	L	PN 315	10	R 1/8" K	8	30	15,0	26	14	19
WR NW 08 HL	L	PN 315	10	R 1/4" K	12	30	15,0	27	14	19
WR NW 08 HL 3/8	L	PN 315	10	R 3/8" K	12	32	17,0	28	17	19
WR NW 08 HL 1/2	L	PN 316	10	R 1/2" K	14	38	23,0	34	19	19
WR NW 10 HL 1/4	L	PN 315	12	R 1/4" K	12	32	17,0	28	17	22
WR NW 10 HL	L	PN 315	12	R 3/8" K	12	32	17,0	28	17	22
WR NW 10 HL 1/2	L	PN 315	12	R 1/2" K	14	38	23,0	34	19	22
WRK NW 10 HL 3/4	L	PN 315	12	R 3/4" K	14	36	21,0	34	19	22
WR NW 13 HL 1/4	L	PN 315	15	R 1/4" K	12	36	21,0	30	19	27
WR NW 13 HL 3/8	L	PN 315	15	R 3/8" K	12	36	21,0	34	19	27
WR NW 13 HL	L	PN 315	15	R 1/2" K	14	36	21,0	34	19	27
WR NW 16 HL 3/8	L	PN 315	18	R 3/8" K	12	40	23,5	34	24	32
WR NW 16 HL	L	PN 315	18	R 1/2" K	14	40	23,5	36	24	32
WR NW 16 HL 3/4	L	PN 160	18	R 3/4" K	16	36	27,5	44	27	32
WRK NW 20 HL	L	PN 160	22	R 3/4" K	16	44	27,5	31	27	36
WR NW 03 HS	S	PN 400	6	R 1/4" K	12	31	16,0	26	12	17
WR NW 04 HS	S	PN 400	8	R 1/4" K	12	32	17,0	27	17	19
WR NW 06 HS	S	PN 400	10	R 3/8" K	12	34	17,5	28	17	22
WR NW 08 HS	S	PN 400	12	R 3/8" K	12	38	21,5	28	17	24
WR NW 08 HS 1/2	S	PN 400	12	R 1/2" K	14	40	23,5	34	19	24
WR NW 10 HS	S	PN 400	14	R 1/2" K	14	40	22,0	32	19	27
WR NW 13 HS	S	PN 400	16	R 1/2" K	14	43	24,5	32	24	30
WR NW 13 HS 3/8	S	PN 400	16	R 3/8" K	12	43	24,5	32	24	30
WR NW 16 HS 1/2	S	PN 400	20	R 1/2" K	14	48	26,5	42	27	36

Ehitusseeria: LL = väga kerge L = kerge S = raske - PN = nimirõhk PB = maks. töörõhk - Ø = toru välisläbimõõt

### Toote variandid

**WRK MG** Sissekeeratav ühendus, nurk 90°, Messing



# WRK

Sissekeeratav liitmik, nurk 90°

**HANSA FLEX**

---