

Omadused

| | |
|--------------------|--|
| Rakendus | Jahutus- ja määrdeainevoolikud metallide lõiketötluseks. |
| Rakendamine | Terasest kandespiraal koos PVC-sisevoolikuga es. Sissekeeratav kiil as. Terasest väljavooludüüs Pealispind on nikliga kaetud |
| Omadused | Täiesti lekkevaba käsitsi mistahes asendisse painutatav stabiilne vastupidav õlidele, rasvadele jne |

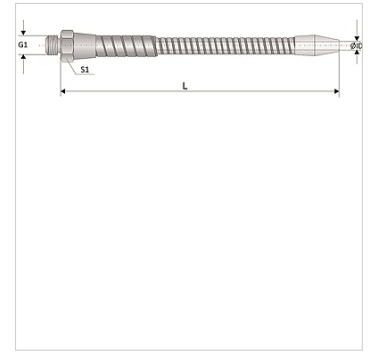

Tellimisinfo

Muud mõõdud soovi korral

Artikkel

| Märgistus | G1 | ID (mm) | S1 (mm) | Nimipikkus (+/-5 mm) |
|--------------|-------------|---------|---------|----------------------|
| NIAG 1/8-200 | R 1/8" | 8,0 | 15,0 | 200 |
| NIAG 1/8-250 | R 1/8" | 8,0 | 15,0 | 250 |
| NIAG 1/8-320 | R 1/8" | 8,0 | 15,0 | 320 |
| NIAG 1/8-400 | R 1/8" | 8,0 | 15,0 | 400 |
| NIAG 1/8-500 | R 1/8" | 8,0 | 15,0 | 500 |
| NIAG 1/8-630 | R 1/8" | 8,0 | 15,0 | 630 |
| NIAG 1/8-800 | R 1/8" | 8,0 | 15,0 | 800 |
| NIAG 1/4-200 | R 1/4 tolli | 10,0 | 19,0 | 200 |
| NIAG 1/4-250 | R 1/4 tolli | 10,0 | 19,0 | 250 |
| NIAG 1/4-320 | R 1/4 tolli | 10,0 | 19,0 | 320 |
| NIAG 1/4-400 | R 1/4 tolli | 10,0 | 19,0 | 400 |
| NIAG 1/4-500 | R 1/4 tolli | 10,0 | 19,0 | 500 |
| NIAG 1/4-630 | R 1/4 tolli | 10,0 | 19,0 | 630 |
| NIAG 1/4-800 | R 1/4 tolli | 10,0 | 19,0 | 800 |
| NIAG 3/8-250 | R 3/8 tolli | 10,0 | 24,0 | 250 |
| NIAG 3/8-300 | R 3/8 tolli | 10,0 | 24,0 | 300 |
| NIAG 3/8-320 | R 3/8 tolli | 10,0 | 24,0 | 320 |
| NIAG 3/8-400 | R 3/8 tolli | 10,0 | 24,0 | 400 |
| NIAG 3/8-500 | R 3/8 tolli | 10,0 | 24,0 | 500 |
| NIAG 3/8-630 | R 3/8 tolli | 10,0 | 24,0 | 630 |
| NIAG 3/8-800 | R 3/8 tolli | 10,0 | 24,0 | 800 |
| NIAG 1/2-250 | R 1/2 tolli | 12,0 | 27,0 | 250 |
| NIAG 1/2-320 | R 1/2 tolli | 12,0 | 27,0 | 320 |
| NIAG 1/2-400 | R 1/2 tolli | 12,0 | 27,0 | 400 |
| NIAG 1/2-500 | R 1/2 tolli | 12,0 | 27,0 | 500 |
| NIAG 1/2-630 | R 1/2 tolli | 12,0 | 27,0 | 630 |
| NIAG 1/2-800 | R 1/2 tolli | 12,0 | 27,0 | 800 |