

Omadused

Rakendus	Jahutus- ja määrdeainevoolikud metallide lõiketötluseks.
Rakendamine	Terasest kandespiraal koos PVC-sisevoolikuga mõlemapoolsed terasest sissekeeratavad liidesed Pealispind on nikliga kaetud
Omadused	Täiesti lekkevaba käsitsi mistahes asendisse painutatav stabiilne vastupidav õlidele, rasvadele jne

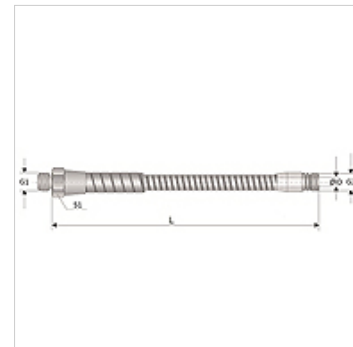

Tellimisinfo

Muud mõõdud soovi korral

Artikkel

Märgistus	G1	G2	ID (mm)	S1 (mm)	Nimipikkus (+/-5 mm)
UPG G1/8-250	R 1/8"	R 1/8 tolli	8,0	15,0	250
UPG G1/8-320	R 1/8"	R 1/8 tolli	8,0	15,0	320
UPG G1/8-400	R 1/8"	R 1/8 tolli	8,0	15,0	400
UPG G1/8-500	R 1/8"	R 1/8 tolli	8,0	15,0	500
UPG G1/4-200	R 1/4 tolli	R 1/4 tolli	10,0	19,0	200
UPG G1/4-250	R 1/4 tolli	R 1/4 tolli	10,0	19,0	250
UPG G1/4-320	R 1/4 tolli	R 1/4 tolli	10,0	19,0	320
UPG G1/4-400	R 1/4 tolli	R 1/4 tolli	10,0	19,0	400
UPG G1/4-500	R 1/4 tolli	R 1/4 tolli	10,0	19,0	500
UPG G1/4-630	R 1/4 tolli	R 1/4 tolli	10,0	19,0	630
UPG G1/4-800	R 1/4 tolli	R 1/4 tolli	10,0	19,0	800
UPG G3/8-200	R 3/8 tolli	R 3/8 tolli	10,0	24,0	200
UPG G3/8-320	R 3/8 tolli	R 3/8 tolli	10,0	24,0	320
UPG G3/8-400	R 3/8 tolli	R 3/8 tolli	10,0	24,0	400
UPG G3/8-500	R 3/8 tolli	R 3/8 tolli	10,0	24,0	500
UPG G3/8-630	R 3/8 tolli	R 3/8 tolli	10,0	24,0	630
UPG G3/8-800	R 3/8 tolli	R 3/8 tolli	10,0	24,0	800
UPG G1/2-500	R 1/2 tolli	R 1/2 tolli	10,0	27,0	500
UPG G1/2-630	R 1/2 tolli	R 1/2 tolli	10,0	27,0	630
UPG G1/2-800	R 1/2 tolli	R 1/2 tolli	10,0	27,0	800