

JG 05 (zyl.)

Sissekeeratav liitmik

Omadused

Rakendusvaldkond	Pneumaatika, vaakumtehnika ja toiduainete valdkond
Ühendus 1	BSP-väliskeere, silindriline
Tihenditüüp 1	sissekeeratava liitmikuga kapseldatud O-rõngas
Ühendus 2	Toruliitmik
Ehitustüüp	Sirge
Tüüp	Sissekeeratav liitmik
Värv	must
Vahendid	Õhk vedelad vahendid inertsed gaasid, nt N ₂ /CO ₂
Materjal	Atsetaalkopolümeerist kere; nitrilkummist O-rõngas

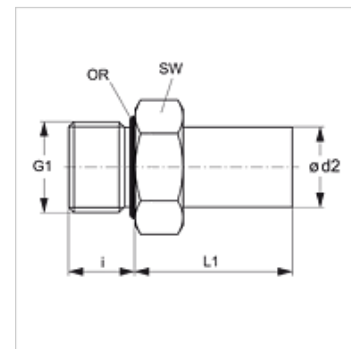

Artikkel

Märgistus	Ø d2 (mm)	G1	i (mm)	L1 (mm)	SW (mm)
JG 05 04 11 E	4	G 1/8" -28	5,5	20	14
JG 05 04 12 E	4	G 1/4" -19	8,0	21	17
JG 05 05 11 E	5	G 1/8" -28	5,5	20	14
JG 05 05 12 E	5	G 1/4" -19	8,0	21	17
JG 05 06 11 E	6	G 1/8" -28	5,5	22	15
JG 05 06 12 E	6	G 1/4" -19	8,0	22	17
JG 05 08 11 E	8	G 1/8" -28	5,5	23	17
JG 05 08 12 E	8	G 1/4" -19	8,0	23	17
JG 05 08 13 E	8	G 3/8" -19	9,5	23	22
JG 05 10 12 E	10	G 1/4" -19	8,0	26	20
JG 05 10 13 E	10	G 3/8" -19	9,5	26	22
JG 05 10 14 E	10	G 1/2" -14	12,5	26	27
JG 05 12 13 E	12	G 3/8" -19	9,5	31	24
JG 05 12 14 E	12	G 1/2" -14	12,5	31	27
JG 05 15 13 E	15	G 3/8" -19	11,5	43	22
JG 05 15 14 E	15	G 1/2" -14	14,5	43	27
JG 05 18 14 E	18	G 1/2" -14	14,5	50	27
JG 05 22 14 E	22	G 1/2" -14	14,5	60	27
JG 05 22 16 E	22	G 3/4" -14	17,0	52	37

Toote variandid

JG 05 N Sissekeeratav liitmik, Messing