

## Omadused

Materjal	NBR
Kasutamine	elektrimootorite ehitustüübile IM B35

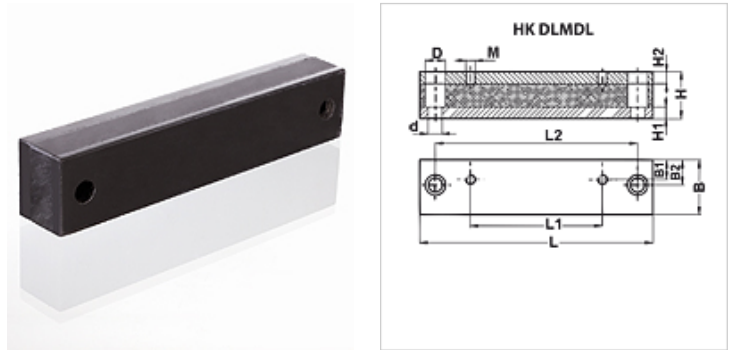

## Kirjeldus

müra ja võngete summutamiseks  
vulkaniseeritud hingav naturaalne kautšuk terasrööbastega  
ülemise ja alumise osa vahel ei ole metallühendust

## Artikkel

Märgistus	IEC mootori ehitussuurus	B	B1	B2	D	d	H	H1	H2	L	L1	L2	M	Kaal
		(mm)	(mm)	(mm)	(mm)	(mm)	(mm)	(mm)	(mm)	(mm)	(mm)	(mm)		(kg)
HK DLMDL 90L	90L	50,00	22,0	25,0	20,0	14,00	40,0	8,00	12	240,0	125,0	205,0	M8	2,10
HK DLMDL 100L	100L	50,00	24,0	25,0	20,0	14,00	40,0	8,00	12	240,0	140,0	205,0	M10	2,25
HK DLMDL 112M	112M	50,00	20,0	25,0	20,0	14,00	40,0	8,00	12	240,0	140,0	205,0	M10	2,30
HK DLMDL 132S	132S	50,00	20,0	25,0	20,0	14,00	45,0	8,00	12	285,0	140,0	245,0	M10	2,42
HK DLMDL 132M	132M	50,00	20,0	25,0	20,0	14,00	45,0	8,00	12	285,0	178,0	245,0	M10	2,42
HK DLMDL 160M	160M	70,00	28,0	35,0	26,0	18,00	60,0	15,00	15	340,0	210,0	300,0	M12	7,50
HK DLMDL 160L	160L	70,00	28,0	35,0	26,0	18,00	60,0	15,00	15	416,0	254,0	370,0	M12	7,50
HK DLMDL 180M	180M	70,00	35,0	35,0	26,0	18,00	60,0	15,00	15	416,0	241,0	370,0	M12	8,00
HK DLMDL 180L	180L	70,00	35,0	35,0	26,0	18,00	60,0	15,00	15	446,0	279,0	400,0	M12	8,00
HK DLMDL 200L	200L	70,00	35,0	35,0	32,0	22,00	60,0	15,00	15	496,0	305,0	430,0	M16	8,55