

## Omadused

Ühendus	Õliühendus: A + B = G 1/2"; lekkeõli = G 1/4"
Rakendamine	Standardmudel Type "C" with standard seal Four hole flange bolt circle 106,4 Võll Ø 32mm
Sisse- ja tagasivoolusurve õlilekke juhtimisega max.	210 bar

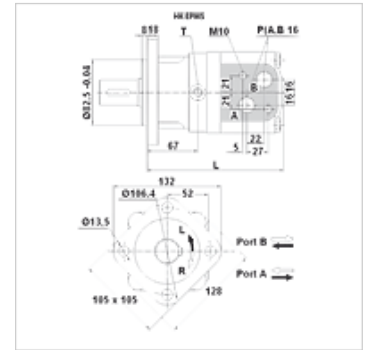

## Vihje

Soovitame ühendada lekkeõli torustiku!

## Artikkel

Märgistus	Läbivool max. (L/min)	Veeväljasurve (cc)	Pöördearv min. (rpm)	Pöördearv max. (rpm)	Pöördemoment max. (N-m)	Survejuhud max. (bar)	Pmax. at 0-100 rpm (bar)	Pmax. at 100-300 rpm (bar)	Pmax. at 300 rpm (bar)	L (mm)	Kaal (kg)
HK EPMS 080 C	65	80,5	10	810	200	175	100	50	20	166	9,8
HK EPMS 100 C	75	100,0	10	750	290	175	100	50	20	169	10,0
HK EPMS 125 C	75	125,7	8	600	370	175	100	50	20	174	10,3
HK EPMS 160 C	75	159,7	8	470	460	150	100	50	20	180	10,7
HK EPMS 200 C	75	200,0	8	375	460	140	100	50	20	187	11,1
HK EPMS 250 C	75	250,0	8	300	500	125	100	50	-	195	11,6
HK EPMS 315 C	75	314,9	8	240	540	120	100	50	-	207	12,3
HK EPMS 400 C	75	397,0	8	185	580	100	100	50	-	221	13,2

max. pressure on shaft seal (without leak oil line) or pressure in leak oil line – Pöördemomendi ja survejuhu väärtused kehtivad püsitalituse puhul – pmax: = max rõhk

## Lisatarvikud

HK V0 590 Löökvantiil

## Varuosad

HK EP DS Hüdraulilise planetaarmootori tihenduskomplekt