

Omadused

Rakendamine	Varbkolbsilinder kinnituselementidega
Töö rõhk	max 200 bar (standardi DIN EN 982 järgi)
Kontrollsurve	max 240 bar (standardi DIN EN 982 järgi)
Temperatuuri ulatus	Standardmudel -15 °C kuni +80 °C
Vahendid	HLP-vedelikud
Materjal	Kolvivarras: Teras 20MnV6, kroom 25 +/- 5 mikronit Kolvivarras: 120-tunnine vastupidavus NSS-testis normi ISO 3768 kohaselt Kolvivarda suunaja: Teras 9SMn28 Öliühendusliitmik: teras 9SMn28 Lihvitud silindritoru: ST 52.3 DIN 2393-ISO H9 Silindri põhi: FE 510-A105 Mutter: teras 8UNI EN20898/2 Tihend TPM: NBR Kolb: teras 9SMn28 Tihend OR: NBR Fluorosil Viton Tihend TSE-TTS-TTI/L: NBR + kate / polüuretaan Tihend GHM-GHK: NBR / polüuretaan

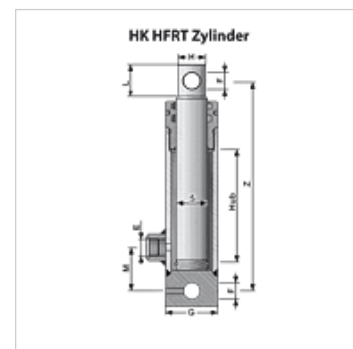

Vihje

Kolbide kiirus standardtihendite suhtes: maks 25 m/min–0,42 m/s.

Kolbide kiirus lõppasendites: maks 6 m/min–0,10 m/s.

For these standard cylinders, it is recommended not to weld any fastenings to the cylinder liner (e.g. cardan mountings) as this could distort it.

Kirjeldus

Our hydraulic cylinders and their components are designed for standard applications in industry and agriculture. They can be used only in some circumstances for applications in construction machinery. If this is your intention, please contact our technical personnel. The cylinders conform to the technical specifications in the catalogue or are designed to customers' specifications (approval drawing).

Jälgige palun silindri valimisel, töötlemisel ja kasutamisel standardi

EN ISO 4413 – Ohutusnõuded vedeliküsteemidele

ja nende komponentidele – juhiseid ja seadusest tulenevatel eeskirjadel põhinevaid määrusi ja ohutusnõudeid.

Artikkel

Märgistus	Ø S (mm)	Keskpunkt (mm)	Z (mm)	Ø E (mm)	M (mm)	Ø H (mm)	L (mm)	Ø F (mm)	Ø G (mm)	Kaal (kg)
HK HFRT 1 25 100	25	100	190	3/8"	40,00	22	35	14,00	40	1,63
HK HFRT 1 25 150	25	150	240	3/8"	40,00	22	35	14,00	40	2,04
HK HFRT 1 25 200	25	200	290	3/8"	40,00	22	35	14,00	40	2,44
HK HFRT 1 25 250	25	250	340	3/8"	40,00	22	35	14,00	40	2,85
HK HFRT 1 25 300	25	300	390	3/8"	40,00	22	35	14,00	40	3,26
HK HFRT 2 30 200	30	200	300	3/8"	42,00	27	37	16,00	50	3,61
HK HFRT 2 30 250	30	250	350	3/8"	42,00	27	37	16,00	50	4,16
HK HFRT 2 30 300	30	300	400	3/8"	42,00	27	37	16,00	50	4,72
HK HFRT 2 30 350	30	350	450	3/8"	42,00	27	37	16,00	50	5,27
HK HFRT 2 30 400	30	400	500	3/8"	42,00	27	37	16,00	50	5,82
HK HFRT 2 30 550	30	550	650	3/8"	42,00	27	37	16,00	50	7,30
HK HFRT 3 40 200	40	200	330	3/8"	47,00	37	49	23,00	60	6,00
HK HFRT 3 40 250	40	250	380	3/8"	47,00	37	49	23,00	60	6,84
HK HFRT 3 40 300	40	300	430	3/8"	47,00	37	49	23,00	60	7,67
HK HFRT 3 40 350	40	350	480	3/8"	47,00	37	49	23,00	60	8,49
HK HFRT 3 40 400	40	400	530	3/8"	47,00	37	49	23,00	60	9,32
HK HFRT 3 40 550	40	550	680	3/8"	47,00	37	49	23,00	60	11,70
HK HFRT 3 40 700	40	700	830	3/8"	47,00	37	49	23,00	60	14,10
HK HFRT 4 50 300	50	300	460	3/8"	50,00	47	65	25,50	65	11,80
HK HFRT 4 50 400	50	400	560	3/8"	50,00	47	65	25,50	65	14,00
HK HFRT 4 50 550	50	550	710	3/8"	50,00	47	65	25,50	65	17,50
HK HFRT 4 50 700	50	700	860	3/8"	50,00	47	65	25,50	65	21,00

Ø S = kolvivarda läbimõõt