

Omadused

Rakendamine	Kombineeritav ühendusega HK ROTEX AF
Materjal	Alumiinium
Kasutamine	For axial piston pump HK PVPC and vane pump HK PFE

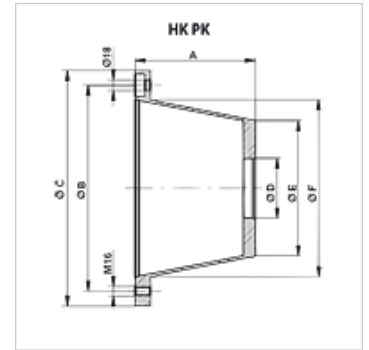

Kirjeldus

Mootori- ja pumbavõlli tsentreerimine

Artikkel

Märgistus	A (mm)	Ø B (mm)	Ø C (mm)	Ø D (mm)	Ø E (mm)	Ø F (mm)	Flantsi pumbaühendus	Pump	Mootor	Kaal (kg)
HK PK 350 040 400	188,00	300	350	101,6	225	260	Kahe auguga flants 146	HKPFE41 / HKPVPC30	BG160	2,9
HK PK 350 060 400	204,00	300	350	101,6	230	260	Kahe auguga flants 146	HKPFE41 / HKPVPC30	BG160/180	3,0
HK PK 350 060 500	204,00	300	350	127,0	230	260	Kahe auguga flants 181	HKPVPC50	BG180	3,0
HK PK 350 101 900	228,00	300	350	127,0	248	260	Kahe auguga flants 181	HKPFE52	BG180	3,3
HK PK 400 040 400	204,00	350	400	101,6	230	300	Kahe auguga flants 146	HKPVPC40	BG200	5,3
HK PK 400 040 600	204,00	350	400	127,0	230	300	Kahe auguga flants 181	HKPVPC50	BG200	5,1
HK PK 400 050 700	228,00	350	400	127,0	279	300	Kahe auguga flants 181	HKPFE52	BG200	5,7
HK PK 450 032 300	262,00	400	450	127,0	315	350	Kahe auguga flants 181	HKPVPC50	BG225	6,6

Lisatarvikud

HK DRV	Summutusrõngas
HK DPT	Pumbakanduri tihend