

Omadused

Ühendus	Õliühendus: A + B = G 1/2"; lekkeõli = G 1/4"
Rakendamine	Economy variant always connect drain line Four hole flange bolt circle 106,4 Võll Ø 32mm
Sisse- ja tagasivoolusurve õlilekke juhtimisega max.	210 bar

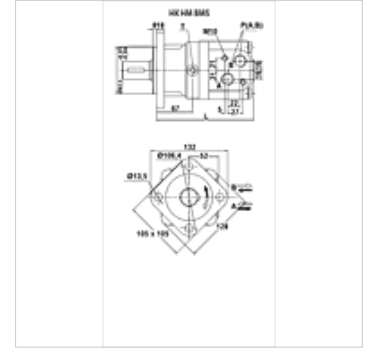

Vihje

Soovitame ühendada lekkeõli torustiku!

Artikkel

Märgistus	Läbivool max. (L/min)	Veeväljasurve (cc)	Pöördearv min. (rpm)	Pöördearv max. (rpm)	Pöördemoment max. (N-m)	Survejuhud max. (bar)	Pmax. at 0-100 rpm (bar)	Pmax. at 100-300 rpm (bar)	Pmax. at 300 rpm (bar)	L (mm)	Kaal (kg)
HK HM BMS 080	65	80,5	10	810	194	175	100	50	20	167	9,8
HK HM BMS 100	75	100,5	10	750	242	175	100	50	20	170	10,0
HK HM BMS 125	75	126,3	8	600	303	175	100	50	20	175	10,3
HK HM BMS 160	75	160,8	8	470	358	160	100	50	20	181	10,7
HK HM BMS 200	75	200,9	8	375	438	160	100	50	20	188	11,1
HK HM BMS 250	75	252,6	8	300	440	125	100	50	-	197	11,6
HK HM BMS 315	75	321,5	8	240	530	125	100	50	-	208	12,3
HK HM BMS 400	75	401,9	8	180	562	100	100	50	-	222	13,2

max. pressure on shaft seal (without leak oil line) or pressure in leak oil line – Pöördemomendi ja survejuhu väärtused kehtivad püsitalituse puhul – pmax: = max rõhk

Lisatarvikud

HK V0 590 Löökventiil

Varuosad

HK HM BM DS Hüdrauliilise planetaarmootori CN tihenduskomplekt