

# LOET HB

Raccord à braser AGR

**HANSA FLEX**

## Caractéristiques

Raccord 1	Branchement de souder
Raccord 2	filet ext. BSP cylindrique
Étanchéité 2	Cône intérieur 60°
Construction	Soldered socket
Conception	droit
Matériau	Acier
Traitement de surface	huilé

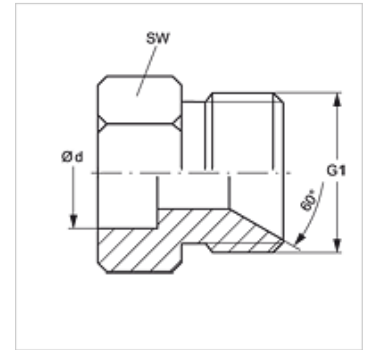

## Article

Désignation	Ø d (mm)	G1	L1 (mm)	SW (mm)
LOET 04 HB 08	8	G 1/4" -19	21,0	19
LOET 04 HB 12	12	G 1/4" -19	21,0	19
LOET 06 HB 14	14	G 3/8" -19	27,0	24
LOET 06 HB 16	16	G 3/8" -19	27,0	24
LOET 08 HB 14	14	G 1/2" -14	29,5	29
LOET 08 HB 16	16	G 1/2" -14	29,5	24
LOET 08 HB 18	18	G 1/2" -14	29,5	29
LOET 08 HB 20	20	G 1/2" -14	32,5	29
LOET 12 HB 20	20	G 3/4" -14	37,5	35
LOET 12 HB 25	25	G 3/4" -14	37,5	35
LOET 16 HB 25	25	G 1" -11	41,0	43
LOET 16 HB 30	30	G 1" -11	41,0	43

Ø d = Diamètre extérieur du tube