

Caractéristiques

Raccord 1	Branchement de souder
Raccord 2	filet extérieur UN/UNF
Étanchéité 2	Cône extérieur 74°
Construction	Soldered socket
Conception	droit
Matériau	Acier
Traitement de surface	huilé

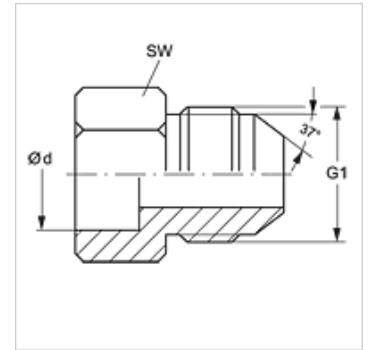

Article

Désignation	Ø d (mm)	G1	L1 (mm)	SW (mm)
LOET 04 HJ 06	6	7/16" -20 UNF	26,0	17
LOET 05 HJ 10	10	1/2" -20 UNF	26,0	19
LOET 06 HJ 10	10	9/16" -18 UNF	27,5	21
LOET 06 HJ 12	12	9/16" -18 UNF	27,5	21
LOET 08 HJ 12	12	3/4" -16 UNF	29,0	26
LOET 08 HJ 16	16	3/4" -16 UNF	29,0	26
LOET 08 HJ 18	18	3/4" -16 UNF	29,0	26
LOET 10 HJ 16	16	7/8" -14 UNF	31,5	30
LOET 10 HJ 18	18	7/8" -14 UNF	31,5	30
LOET 10 HJ 22	22	7/8" -14 UNF	36,5	30
LOET 12 HJ 18	18	1 1/16" -12 UN	40,0	37
LOET 12 HJ 20	20	1 1/16" -12 UN	40,0	37
LOET 12 HJ 25	25	1 1/16" -12 UN	40,0	37
LOET 16 HJ 25	25	1 5/16" -12 UN	42,0	45
LOET 16 HJ 27	27	1 5/16" -12 UN	42,0	45
LOET 16 HJ 32	32	1 5/16" -12 UN	42,5	45
LOET 20 HJ 32	32	1 5/8" -12 UN	45,0	55
LOET 20 HJ 38	38	1 5/8" -12 UN	43,5	50
LOET 24 HJ 38	38	1 7/8" -12 UN	45,5	50
LOET 50 HJ 32	32	2 1/2" -12 UN	-	-

Ø d = Diamètre extérieur du tube