

W45 AN HN

Manchon fileté, coude 45°

Caractéristiques

Raccord 1	filetage femelle NPT (NPSM)
Étanchéité 1	Cône extérieur 60°
Raccord 2	filet extérieur NPT
Étanchéité 2	étanchéité par filetage
Construction	Manchon fileté
Conception	Coude 45°
Matériau	Acier
Traitement de surface	revêtement galvanisé

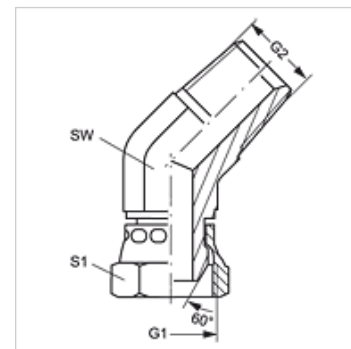

Article

Désignation	G1	G2	SW (mm)	S1
W45 AN 02 HN	1/8" -27 NPT	1/8" -27 NPT	11	14
W45 AN 04 HN	1/4" -18 NPT	1/4" -18 NPT	14	18
W45 AN 06 HN	3/8" -18 NPT	3/8" -18 NPT	19	22
W45 AN 06 HN 08	3/8" -18 NPT	1/2" -14 NPT	22	22
W45 AN 08 HN	1/2" -14 NPT	1/2" -14 NPT	22	25
W45 AN 08 HN 12	1/2" -14 NPT	3/4" -14 NPT	27	25
W45 AN 12 HN	3/4" -14 NPT	3/4" -14 NPT	27	32
W45 AN 12 HN 16	3/4" -14 NPT	1" -11,5 NPT	33	32
W45 AN 16 HN 12	1" -11,5 NPT	3/4" -14 NPT	33	38
W45 AN 16 HN	1" -11,5 NPT	1" -11,5 NPT	33	38
W45 AN 20 HN	1 1/4" -11,5 NPT	1 1/4" -11,5 NPT	41	48
W45 AN 24 HN	1 1/2" -11,5 NPT	1 1/2" -11,5 NPT	48	54
W45 AN 32 HN	2" -11,5 NPT	2" -11,5 NPT	64	67

SW, S1, S2 = largeur de clé