

W45 O AN

Manchon fileté, coude 45°

Caractéristiques

Raccord 1	Filetage extérieur UN/UNF
Étanchéité 1	Étanchéité par joint torique sur manchon fileté
Raccord 2	filetage femelle NPSM
Étanchéité 2	Cône extérieur 60°
Construction	Manchon fileté, direction réglable
Conception	Coude 45°
Matériau	Acier
Traitement de surface	revêtement galvanisé

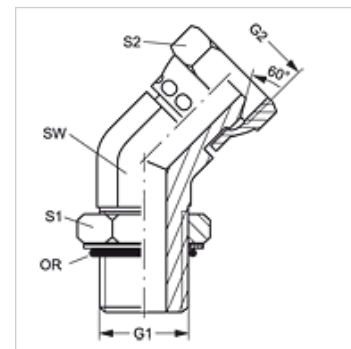

Article

Désignation	G1	G2	SW (mm)	S1	S2	Joint torique
W45 O 04 AN	7/16" -20 UNF	1/4" -18 NPT	11	14	18	8,92 x 1,83
W45 O 06 AN 04	9/16" -18 UNF	1/4" -18 NPT	14	22	14	11,90 x 1,98
W45 O 06 AN	9/16" -18 UNF	3/8" -18 NPT	14	18	22	11,90 x 1,98
W45 O 08 AN 06	3/4" -16 UNF	3/8" -18 NPT	19	22	22	16,36 x 2,20
W45 O 08 AN	3/4" -16 UNF	1/2" -14 NPT	19	22	25	16,36 x 2,20
W45 O 08 AN 12	3/4" -16 UNF	3/4" -14 NPT	19	22	32	16,36 x 2,20
W45 O 10 AN 08	7/8" -14 UNF	1/2" -14 NPT	22	25	25	19,18 x 2,46
W45 O 12 AN	1 1/16" -12 UN	3/4" -14 NPT	27	32	32	23,47 x 2,95

SW, S1, S2 = largeur de clé