

G VKS ST 250

Bride carrée, Cetop, collerette à souder

HANSA FLEX

Caractéristiques

Construction Bride carrée Cetop

Conception droit

Norme CETOP RP 63H
ISO 6164

Matériau S355J2G3 (ST52.3)

Traitement de surface huilé noir

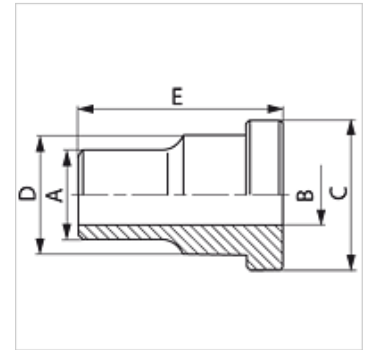
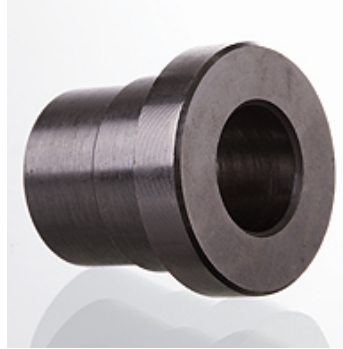

Article

| Désignation | Pression PB (bar) | Gabarit | A (mm) | Ø B (mm) | C (mm) | D (mm) | E (mm) |
|------------------|----------------------|---------|-----------|-------------|-----------|-----------|-----------|
| G VKS 38 ST 250 | 250 | 3/8" | 18 | 12,5 | 24,5 | 18,0 | 30 |
| G VKS 12 ST 250 | 250 | 1/2" | 22 | 15,0 | 30,2 | 24,0 | 30 |
| G VKS 34 ST 250 | 250 | 3/4" | 28 | 20,0 | 38,1 | 31,5 | 35 |
| G VKS 1 ST 250 | 250 | 1" | 35 | 25,0 | 44,4 | 38,0 | 40 |
| G VKS 114 ST 250 | 250 | 1.1/4" | 43 | 32,0 | 50,8 | 43,0 | 45 |
| G VKS 112 ST 250 | 250 | 1.1/2" | 50 | 38,0 | 60,3 | 50,0 | 50 |
| G VKS 2 ST 250 | 250 | 2" | 62 | 47,0 | 71,4 | 62,0 | 60 |
| G VKS 212 ST 250 | 250 | 2.1/2" | 76 | 58,0 | 87,2 | 76,0 | 70 |
| G VKS 3 ST 250 | 250 | 3" | 90 | 70,0 | 101,6 | 90,0 | 80 |
| G VKS 312 ST 250 | 250 | 3.1/2" | 102 | 80,0 | 119,0 | 102,0 | 90 |
| G VKS 4 ST 250 | 250 | 4" | 114 | 90,0 | 131,0 | 114,0 | 105 |

PN = Pression nominale PB = Pression de service max. - Série : LL = très léger L = léger S = lourd