

# GE O AN

## Manchon fileté

### Caractéristiques

|                       |   |
|-----------------------|---|
| Raccord 1             | Filetage extérieur UN/UNF                       |
| Étanchéité 1          | Étanchéité par joint torique sur manchon fileté |
| Raccord 2             | filetage femelle NPSM                           |
| Étanchéité 2          | Cône extérieur 60°                              |
| Construction          | Manchon fileté                                  |
| Conception            | droit   |
| Matériau              | Acier   |
| Traitement de surface | revêtement galvanisé                            |

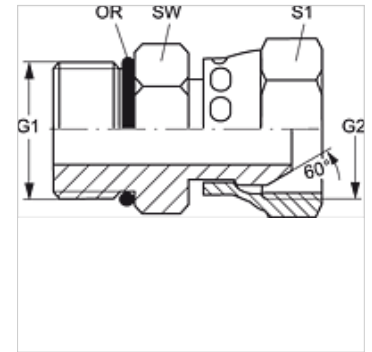

### Article

| Désignation   | G1             | G2           | SW<br>(mm) | S1 | Joint torique |
|---------------|----------------|--------------|------------|----|---------------|
| GE O 04 AN    | 7/16" -20 UNF  | 1/4" -18 NPT | 14         | 18 | 8,92 x 1,83   |
| GE O 06 AN    | 9/16" -18 UNF  | 3/8" -18 NPT | 18         | 22 | 11,90 x 1,98  |
| GE O 06 AN 08 | 9/16" -18 UNF  | 1/2" -14 NPT | 19         | 25 | 11,90 x 1,98  |
| GE O 08 AN    | 3/4" -16 UNF   | 1/2" -14 NPT | 22         | 25 | 16,36 x 2,20  |
| GE O 08 AN 12 | 3/4" -16 UNF   | 3/4" -14 NPT | 25         | 32 | 16,36 x 2,20  |
| GE O 10 AN 06 | 7/8" -14 UNF   | 3/8" -18 NPT | 22         | 25 | 19,18 x 2,46  |
| GE O 10 AN 08 | 7/8" -14 UNF   | 1/2" -14 NPT | 25         | 25 | 19,18 x 2,46  |
| GE O 12 AN 08 | 1 1/16" -12 UN | 1/2" -14 NPT | 32         | 25 | 23,47 x 2,95  |
| GE O 12 AN    | 1 1/16" -12 UN | 3/4" -14 NPT | 32         | 32 | 23,47 x 2,95  |
| GE O 16 AN    | 1 5/16" -12 UN | 1" -11,5 NPT | 38         | 38 | 29,74 x 2,95  |

SW, S1, S2 = largeur de clé