

Caractéristiques

Ajout de construction pour tubes en plastique en PA 11/12

Construction Douilles de renforcement

Matériau Laiton

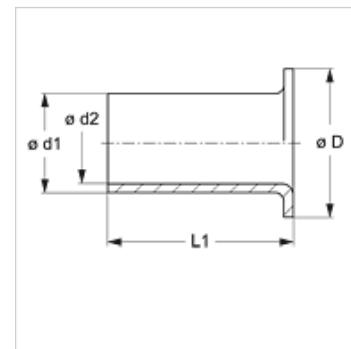

Article

Désignation	D (mm)	Ø d1 (mm)	Ø d2 (mm)	L1 (mm)
TR 04-1 EH	3,5	2,0	1,3	8
TR 06-1 EH	5,0	4,0	3,2	10
TR 06-1.5 EH	5,0	3,0	2,2	10
TR 08-1 EH	8,0	6,0	5,0	15
TR 08-1.5 EH	8,0	5,0	4,0	15
TR 10-1 EH	10,0	8,0	6,7	15
TR 10-1.25 EH	10,0	7,5	6,5	10
TR 10-1.5 EH	10,0	7,0	-	-
TR 12-1 EH	12,0	10,0	8,7	15
TR 12-1.5 EH	12,0	9,0	7,7	15
TR 12-2 EH	12,0	8,0	6,7	15
TR 15-1.5 EH	14,0	12,0	10,7	15
TR 15-2 EH	14,0	11,0	7,0	15
TR 18-2 EH	17,8	14,0	12,7	18
TR 20-2 EH	17,8	16,0	14,7	18
TR 22-2 EH	21,8	18,0	16,7	20
TR 25-2.5 EH	21,8	20,0	18,7	20