

SRS AS 30-100 V4

Vis à six pans creux pour collier pour 1 tube

HANSA FLEX

Caractéristiques

Construction pour colliers pour 1 tube

Série lourde

Norme DIN 931 (ISO 4014) ou DIN 933 (ISO 4017)

Matériau Acier inoxydable 1.4571

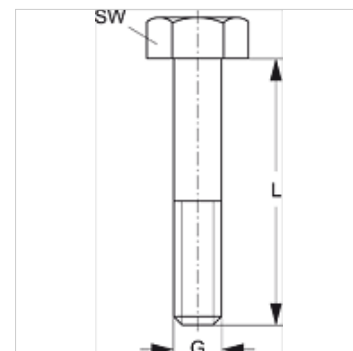

Article

Désignation	Taille de collier	G	L (mm)	SW (mm)
SRS AS 30 V4	1	M 10	40	17
SRS AS 40 V4	2	M 10	60	17
SRS AS 50 V4	3	M 10	70	17
SRS AS 60 V4	4	M 12	100	19
SRS AS 70 V4	5	M 16	130	24
SRS AS 80 V4	6	M 20	190	30

Gamme de produits

SRS AS 30-100 Vis à six pans creux pour collier pour 1 tube, Acier