

K 403-01 - K 403-17

Bague d'étanchéité pour raccord bout à bout

HANSA FLEX

Caractéristiques

Norme DIN 74297

Matériau Fibre vulcanisée

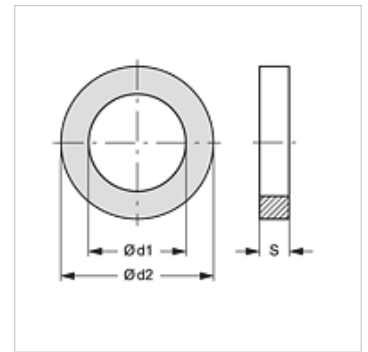

Article

Désignation	$\varnothing d1$ (mm)	$\varnothing d2$ (mm)	S (mm)
K 403-01	7	15	1,50
K 403-03	15	24	1,50
K 403-11	22	27	1,50