

# HK DPT

Joint pour support de pompe

**HANSA FLEX**

## Caractéristiques

Hauteur de joint	2 mm
Matériau	NBR

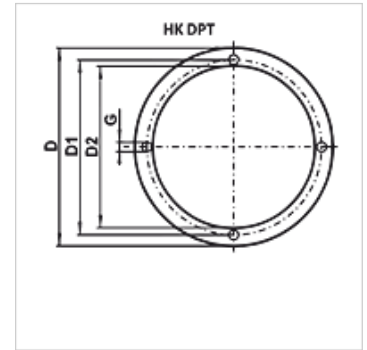

## Description

Pour utilisation entre le support de pompe et la plaque de montage

## Article

Désignation	Gabarit moteur IEC	Ø D (mm)	Ø D1 (mm)	Ø D2 (mm)	Ø G (mm)	Poids (kg)
HK DPT 160 NBR	71A / 71B	160,0	130,0	112,0	10	0,05
HK DPT 200 NBR	80A / 80B / 90S / 90L	200,0	165,0	147,0	12	0,05
HK DPT 250 NBR	100L / 112M	250,0	215,0	193,0	14	0,05
HK DPT 300 NBR	132S / 132M	300,0	265,0	235,0	14	0,08
HK DPT 350 NBR	160M / 160L / 180M / 180L	350,0	300,0	261,0	19	0,10
HK DPT 400 NBR	200L	400,0	350,0	301,0	19	0,16