

HK FL

Palier pivotant FL

Caractéristiques

Matériau Acier S355J0 (Fe510C)

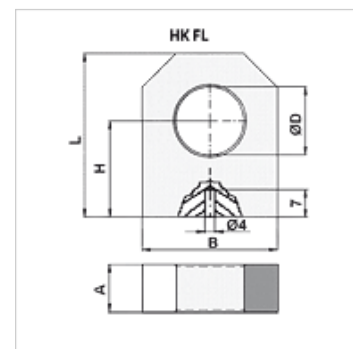

Article

Désignation	A (mm)	B (mm)	H (mm)	L (mm)	Ø D (mm)	Poids (kg)
HK FL 16	15,0	35,0	34,0	50,0	16,20	0,19
HK FL 20	20,0	40,0	40,0	60,0	20,25	0,38
HK FL 25	25,0	50,0	45,0	65,0	25,25	0,58
HK FL 30	30,0	60,0	50,0	75,0	30,25	0,79
HK FL 35	35,0	70,0	55,0	85,0	35,25	0,98
HK FL 40	40,0	80,0	60,0	100,0	40,25	1,22