

### Caractéristiques

|                            |                                        |
|----------------------------|----------------------------------------|
| Construction               | Garniture chevron                      |
| Pression de service        | jusqu'à 500 bar                        |
| Vitesse de glissement max. | 0,5 m/s                                |
| Température min.           | -30 °C                                 |
| Température max.           | 110 °C                                 |
| Médiums                    | Huiles minérales<br>Émulsions aqueuses |
| Montage                    | sur pistons en plusieurs pièces        |
| Application                | Hydraulique                            |

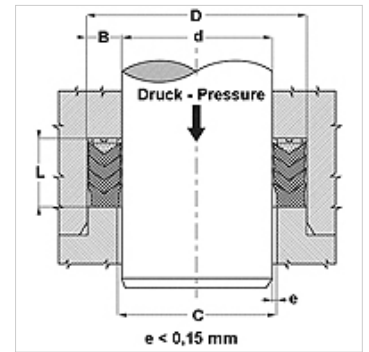
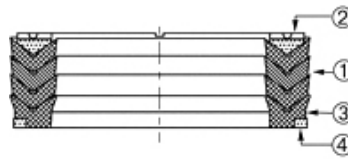

### Article

| Désignation      | d<br>(mm) | D<br>(mm) | L<br>(mm) |
|------------------|-----------|-----------|-----------|
| CH-375 325-NEO   | 82,55     | 95,25     | 21,72     |
| CH-425 350-NEO   | 88,90     | 107,95    | 31,00     |
| CH-450 350-NEO   | 88,90     | 114,30    | 35,32     |
| CH-450 375-NEO   | 95,25     | 114,30    | 25,40     |
| CH-450 387-NEO   | 98,42     | 114,42    | 26,59     |
| CH-500 425-NEO   | 107,95    | 127,00    | 30,00     |
| CH-550 450-1-NEO | 114,30    | 139,70    | 33,50     |
| CH-551 452-NEO   | 115,00    | 140,00    | 37,12     |
| CH-590 472-NEO   | 120,00    | 150,00    | 44,00     |
| CH-600 500-NEO   | 127,00    | 152,40    | 38,63     |
| CH-629 511-1-NEO | 130,00    | 160,00    | 43,50     |
| CH-826 708-B-NEO | 180,00    | 210,00    | 32,97     |
| CH-875 750-NEO   | 190,50    | 222,25    | 50,00     |
| CH-110 2984B-NEO | 250,00    | 280,00    | 32,97     |

BD = pression de service