

## Caractéristiques

Construction	Segment de piston
Pression de service	jusqu'à 400 bar
Vitesse de glissement max.	0,5 m/s
Température min.	-30 °C
Température max.	80 °C
Médiums	Huiles minérales
Montage	sur pistons d'une seule pièce A sur pistons en plusieurs pièces B
Matériau	(2) Joint : PUR
Application	Hydraulique

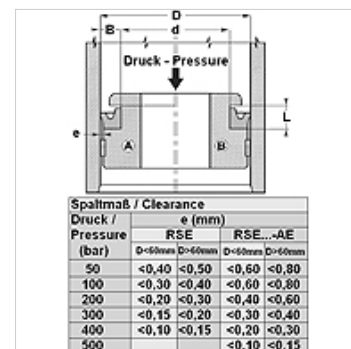

Toleranz / Tolerance		
D	d	L
H10 / e8	+0,10 0	+0,20 0



## Remarque

Les joints de piston ne conviennent pas aux pistons à double effet. Veuillez prendre contact avec nous.

## Description

Forte résistance à l'abrasion.

Bonne étanchéité.

Solution simple.

## Article

Désignation	D (mm)	d (mm)	L (mm)	M (mm)
RSE 12 05	12,0	5,0	6,0	8
RSE 14 08	14,0	8,0	6,8	11
RSE 16 10-1	16,0	10,0	6,5	13
RSE 16 10	16,0	10,0	9,0	13
RSE 20 12	20,0	12,0	7,5	15
RSE 20 14	20,0	14,0	6,0	17
RSE 22 12	22,0	12,0	9,0	16
RSE 25 15	25,0	15,0	9,0	19
RSE 30 15	30,0	15,0	11,0	19
RSE 30 20	30,0	20,0	9,0	24
RSE 30 22	30,0	22,0	7,0	25
RSE 32 22	32,0	22,0	11,0	26
RSE 32 26	32,0	26,0	6,0	28
RSE 35 20	35,0	20,0	11,0	25
RSE 35 25	35,0	25,0	9,0	29
RSE 37 21	37,0	21,0	13,0	25
RSE 40 25-1	40,0	25,0	10,0	30
RSE 40 25	40,0	25,0	11,0	30
RSE 40 30-1	40,0	30,0	7,5	34
RSE 40 30	40,0	30,0	11,0	34
RSE 40 32-2	40,0	32,0	6,5	36
RSE 40 32	40,0	32,0	9,0	36
RSE 40 33	40,0	33,0	9,0	36
RSE 42 32	42,0	32,0	11,0	36
RSE 42 35	42,0	34,5	4,7	37
RSE 45 29	45,0	38,5	13,0	33
RSE 45 30	45,0	30,0	11,0	35
RSE 50 30	50,0	30,0	13,0	35
RSE 50 32	50,0	32,0	11,0	35
RSE 50 35-1	50,0	35,0	9,5	40
RSE 50 35	50,0	35,0	11,0	40
RSE 50 40-1	50,0	40,0	5,5	44
RSE 50 40	50,0	40,0	11,0	44
RSE 50 42-2	50,0	42,0	6,0	45
RSE 50 42-1	50,0	42,0	9,0	45
RSE 50 42	50,0	42,0	11,0	45
RSE 51 41	50,8	40,8	8,0	45
RSE 55 40	55,0	40,0	11,0	45

Article				
Désignation	D (mm)	d (mm)	L (mm)	M (mm)
RSE 60 40	60,0	40,0	13,0	45
RSE 60 40-1	60,0	40,0	14,5	45
RSE 60 45	60,0	45,0	11,0	50
RSE 60 50	60,0	50,0	8,0	54
RSE 60 50-2	60,0	50,0	11,0	54
RSE 60 52	60,0	52,0	9,0	55
RSE 63 43	63,0	43,0	13,0	47
RSE 63 45	63,0	45,0	11,0	50
RSE 63 45-2	63,0	45,0	13,0	50
RSE 63 48-1	63,0	48,0	11,0	53
RSE 63 48	63,0	48,0	13,0	53
RSE 63 53	63,0	53,0	8,0	57
RSE 63 53-1	63,0	53,0	13,0	57
RSE 65 45-1	65,0	45,0	13,0	50
RSE 65 45	65,0	45,0	14,5	50
RSE 65 50	65,0	50,0	11,0	55
RSE 65 55-1	65,0	55,0	11,0	59
RSE 65 55	65,0	55,0	14,5	59
RSE 70 50	70,0	53,0	13,0	55
RSE 70 50-1	70,0	53,0	14,5	55
RSE 70 55-1	70,0	55,0	10,5	60
RSE 70 55	70,0	55,0	13,0	60
RSE 70 60	70,0	60,0	8,0	64
RSE 70 60-1	70,0	60,0	13,0	64
RSE 70 60-2	70,0	60,0	14,5	64
RSE 70 62	70,0	62,0	8,5	65
RSE 72 58	72,0	58,0	13,0	62
RSE 75 50	75,0	50,0	15,0	55
RSE 75 55	75,0	55,0	14,5	60
RSE 75 65-4	75,0	65,0	8,0	69
RSE 75 65-2	75,0	65,0	11,0	69
RSE 75 65	75,0	65,0	14,5	69
RSE 80 60	80,0	60,0	13,0	65
RSE 80 60-1	80,0	60,0	14,5	65
RSE 80 65	80,0	65,0	13,0	70
RSE 80 70	80,0	70,0	8,0	74
RSE 80 70-1	80,0	70,0	13,0	74
RSE 80 72	80,0	72,0	13,0	75
RSE 85 65-2	85,0	65,0	13,0	70
RSE 90 70	90,0	70,0	13,0	75
RSE 90 70-1	90,0	70,0	14,5	75
RSE 90 75	90,0	75,0	13,0	80
RSE 90 80-2	90,0	80,0	5,5	84
RSE 90 80-1	90,0	80,0	11,0	84
RSE 90 80	90,0	80,0	14,0	84
RSE 100 80-2	100,0	80,0	11,0	85
RSE 100 80	100,0	80,0	13,0	85
RSE 100 80-1	100,0	80,0	14,5	85
RSE 100 85	100,0	85,0	13,0	90
RSE 100 86	100,0	86,0	13,0	90
RSE 100 90	100,0	90,0	8,0	94
RSE 100 90-1	100,0	90,0	11,5	94
RSE 110 90	110,0	90,0	13,0	95
RSE 110 95	110,0	95,0	13,0	100
RSE 110 100	110,0	100,0	8,0	104
RSE 110 100-1	110,0	100,0	14,5	104
RSE 115 100	115,0	100,0	11,5	105
RSE 115 105	115,0	105,0	14,5	109
RSE 120 100	120,0	100,0	13,0	105
RSE 120 100-1	120,0	100,0	14,5	105
RSE 125 105	125,0	100,0	13,0	110
RSE 125 105-1	125,0	100,0	16,0	110
RSE 125 115	125,0	115,0	8,0	119



### Article

Désignation	D (mm)	d (mm)	L (mm)	M (mm)
RSE 125 115-1	125,0	115,0	16,0	119
RSE 140 120	140,0	120,0	13,0	125
RSE 150 125	150,0	125,0	14,5	130
RSE 150 130	150,0	130,0	16,0	135
RSE 160 140	160,0	140,0	14,5	145
RSE 180 160	180,0	160,0	14,5	165
RSE 280 250	280,0	250,0	19,0	256