

# K-SAUGPLATTENAUFHAENGUNG

Flexible suction pad mountings

**HANSA FLEX**

## Caractéristiques

**Application** For handling of workpieces with sloping using large-area vacuum gripper  
Handling of large plates that can sag when lifting  
In combination with spring plungers to compensate height-differences and Uneveness

**Caractéristiques** very good adaptation to oblique workpiece surfaces  
automatic reset in startposition  
vacuum-tight design with integrated protection against damage

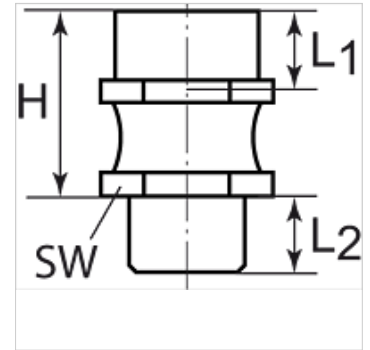

## Remarque

Autres informations sur demande.

## Description

Flexible suction pad mounting. By flexing in all directions, this mounting allows the suction pad to better adapt itself to sloping workpieces.

## Article

Désignation	Filetage 1 intérieur	Filetage 2 extérieur	H (mm)	Matériau	L1 (mm)	L2 (mm)	Angle W (°)	Charge verticale (N/m <sup>2</sup> )	Moment fléchissant (N/m <sup>2</sup> )	SW (mm)
K- 07 45 01 47	G 1/4	M 10 x 1.25	27,0	Steel, rubber	10,5	8,0	12	500	8,0	17
K- 07 45 01 48	G 1/4	G 1/4	27,0	Steel, rubber	12,0	12,0	12	750	10,0	17