

K-PNEU ENTSPRV SCHL AG

Pneumatically piloted stop valves, pipe - thread

Caractéristiques

Pression de service	maxi 10 bar
Débit 6,3 bar, p=1 bar	400 NI/min (Ø 6), 790 NI/min (Ø 8)
Raccord pneumatique de commande	4 mm
Plage de température	-20 °C to +60 °C
Corps	Technopolymer
Pièces internes	nickel-plated brass, brass, \ ntechnopolymer, stainless steel
Matériau étanche	NBR
Montage	Wall mounting (housing with drilled holes) Bracket mounting (mounting bracket available) Panel mounting (with bracket or lock nut)
Symbole	on the housing

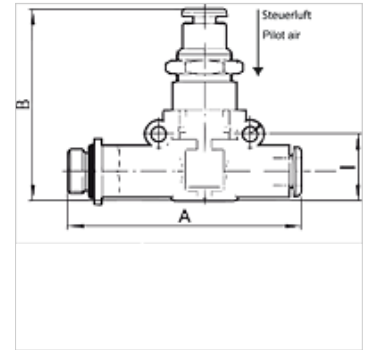
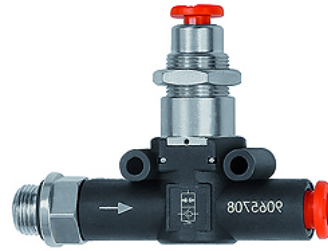

Remarque

Autres informations sur demande.

Description

A carefully selected assortment of products for installation in pneumatic circuits. These small, highly efficient components allow all pneumatic functions to be implemented anywhere in the circuit. The series has an ultramodular design.
All components can be installed In parallel, In series, In a mixed parallel / serial configuration. Available as Pipe / pipe connection with two plug connectors Thread / pipe connection, with one plug connector and one nickel-plated brass thread.

Article

Désignation	Filets	pour Ø de tuyau (mm)	A (mm)	B (mm)	l (mm)
K- 07 15 25 57	G 1/8	6	58,5	43,2	14,6
K- 07 15 25 58	G 1/8	8	66,2	49,7	18,7
K- 07 15 25 55	G 1/4	6	61,5	43,2	14,6
K- 07 15 25 56	G 1/4	8	70,6	49,7	18,7
K- 07 15 25 59	G 3/8	8	72,2	49,7	18,7