

K-WV 5/2 MECHA ROLLENHEBEL M5

5/2-way valve, mechanically operated, with roller lever

HANSA FLEX

Caractéristiques

| | |
|------------------------------|---|
| Pression de service | 0 - 10 bar |
| Plage de température | -20 °C to +70 °C |
| Mesure de la valeur du débit | At P1 = 8 bar, P2 = 6 bar and pressure drop $\Delta p = 1$ bar |
| Corps de vanne | Aluminium alloy |

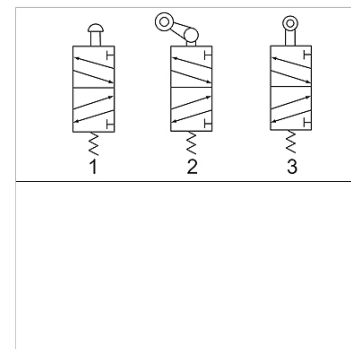

Remarque

Autres informations sur demande.

Article

| Désignation | Raccord | Raccord de ventilation | Débit (L/min) | Schéma numéro |
|----------------|---------|------------------------|---------------|---------------|
| K- 07 15 03 12 | G 1/8 | G 1/8 | 450 | 3 |
| K- 07 15 03 13 | G 1/4 | G 1/8 | 550 | 3 |