

# K-KONSOLE STAHL VS INFI

Console made of steel galvanized

## Caractéristiques

Matériau Galvanised steel

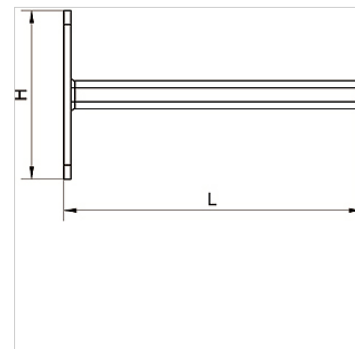
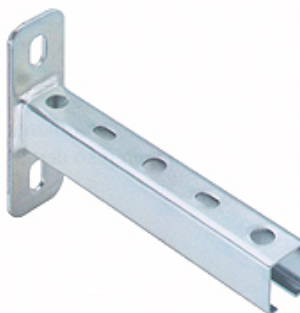

## Article

Désignation	H (mm)	L (mm)	Longueur (m)
K- 07 40 54 90	120,0	280,0	0,280